

Engine

Engine: Imported Cummins engine with type of QSB6.7 inline 6-cylinder water-cooled diesel engine, displacement 6.7L.

Maximum power: 127kW/2000r/min

Maximum torque: 658N·m/1500r/min

Emission standard: Tier III

Air filter: Twin-stage filter composed of air prefilter and air packed bed filter.

Fuel tank: capacity cubage 230L.

Electric gasoline pump: 20L/min.

Optional imported Cummins engine with the model of 6BTA-C167.

Maximum power: 124Kw /2000rpm.

Maximum torque: 651N·m/1500rpm.

Electric Control System

The system is composed of multi-controllers, displays and sensors.

The data transmissions among the controllers, displays, engines, remote control termination of the moment limiter adopt CAN network technology and the system is with high reliability.

The display is able to indicate the parameters of the rotation speed of the engines, amount of fuel, pressure of engine oil, servo pressure, wind speed and engine' operation time. It is also equipped with the function such as for indicating the locking of the main winch and the auxiliary winch and locking of the main and auxiliary luffing, and locking of the swing.

Hydraulic System

Two configuration choices for hydraulic system: Bosch Rexroth (R) and Kawasaki (K). Both of the two have inching function.

Bosch Rexroth (R) Pump Set: Two variable displacement pumps, axial piston-bent axis design (main pump plus servo-pump), a variable displacement pump, axial piston-variable swashplate design (rotary pump) and a gear pump. The Control mode of the main pump is LA0, i.e. the aggregate capacity adjustment, and the electron capacity adjusts override control and it is also able to achieve load sensitive function.

Bosch Rexroth (R) Main Valve: it is integral multiple unit valve, which can achieve the flow distribution un-rely on load pressure (LUDV).

LUDV is load unrelated distributing valve. If the situation of lacking of flow appears inside the system, that is, the oil pump cannot provide enough flow, then it cannot drive the components in accordance with the required speed, in this case, the speed of each component shall be lowered down according to this rate.

Independent Closed Circuit Type Swing System.

Kawasaki (K) Pump Set: The positive control with the summation power control is taken by the main hydraulic pump. The displacement of main pump is in direct proportion to the control signal; when sum of export pressure of the dual pump reaches a set value, the variable-displacement mechanisms of

the dual pump will act simultaneously to reduce the displacement of the oil pump and ensure a constant output total power of the pump. In addition, when the wing pump and the main pump works simultaneously, cross power control is enabled to ensure that the engine will not be overloaded.

Kawasaki (K) main valve: it is of a Sandwich calve-control block with relieving through neutral position. The control block was controlled proportionally by the oil pilot valve. At upstream of each piece of valve in the block, the pressure compensators is used to reduce the changing of the flow rates favorable adaptability for the driver during manipulation.

Independent opened circuit type swing system.

Hydraulic System Elements

Main / Auxiliary Winch Motor: Plug-in type motor (only Rexroth) shall reduce the dimensions of the structure.

R: It is a variable displacement plug-in motor with an axial tapered piston rotary group of bent axis design with balance valve, hidden wet brake.

K: It is a variable displacement plug-in motor with an axial tapered piston rotary of bent swashplate design with balance valve, hidden wet brake.

Luffing Motor: Plug-in R type motor reduces the dimensions of the structure.

R: It is a variable displacement plug-in motor with an axial tapered piston rotary group of bent axis design with balance valve, hidden wet brake.

K: It is a variable displacement plug-in motor with an axial tapered piston rotary of bent swashplate design with balance valve, hidden wet brake.

Swing Motor: Plug-in type motor shall reduce the dimensions of the structure;

R: It is a variable displacement plug-in motor with an axial tapered piston rotary group of bent axis design with hidden wet brake.

K: It is a variable displacement plug-in motor with an axial tapered piston rotary of bent swashplate design hidden wet brake.

Traveling Motor: It is a variable displacement plug-in motor with an axial tapered piston rotary group of bent axis design with balance valve, and hidden wet brake. Plug-in type motor shall reduce the dimensions of the structure.

Oil Cooler: It is a hydraulic oil radiator directly driven by hydraulic motor.

Hydraulic Oil Tank: volume 260L.

Main/Auxiliary Hoisting Mechanism

The main and auxiliary hoisting winches shall be driven separately. The drum shall be directly driven by the hoisting motor through the reducer. By manipulating the hoist lever, the bidirectional rotation of winches, the hooks hoisting and lowering are actuated.

Upperworks

Drum: The LEBUS drum ensures that the cable will not get snarled even when conducting multilayer winding. The drum is fixed onto the platform with the supporting plates at 2 sides.

Braking: Closed, concealed, wet type, spring loaded, and pressure released spring brake

The hoisting Gear Assembling and Disassembling: After connecting the hoisting gear (including drum, motor, reducer, balance valve and supporting plate) integrally install it onto the main platform, and then hinge the hoisting gear and the main platform with pin. When disassembling, it is allowed to only remove the connecting pin and remove the hoisting gear integrally away from the platform.

Main Hoisting Gear (R)	Drum Diameter	420mm
	Outermost cable speed	0~102m/min (High Speed)
		0~63m/min (Low Speed)
	Diameter of Steel Wire	20mm
	Length of steel wire for main winch	180m
	Length of steel wire for auxiliary winch	130m
	Rated Single wire pull	6.1t

Main Hoisting Mechanism (K)	Drum Diameter	470mm
	Outermost cable speed	0~120m/min
	Diameter of Steel Wire	20mm
	Length of steel wire for main winch	180m
	Length of steel wire for auxiliary winch	130m
	Rated Single wire pull	6.1t

Luffing Mechanism

The drum shall be directly driven by luffing motor through the reducer. By manipulating the luffing lever, the bidirectional rotation of drum, that means the rising and lowering of the crane boom, shall be actuated.

Braking: Closed, concealed, wet type, spring loaded, and pressure released spring brake

Drum: The LEBUS drum ensures that the cable will not get snarled even when conducting multilayer winding. The drum is fixed onto the platform with the supporting plate.

The hoisting Gear Assembling and Disassembling: After

connecting the luffing mechanism (including drum, motor, reducer, balance valve and supporting plate) integrally install it onto the main platform, and then fix it onto the main platform with bolt. When disassembling, it is allowed to remove integrally away from the platform.

Luffing Mechanism (R)	Drum Diameter	290.8mm
	Outermost cable speed	0~73m/min
	Diameter of Steel Wire	16mm
	Length of steel wire for luffing	142mm
	Rated Single wire pull	3.7t
Luffing Devices (K)	Drum Diameter	420mm
	Outermost cable speed	0~90m/min
	Diameter of Steel Wire	16mm
	Length of steel wire for swing	142mm
	Rated Single wire pull	3.7t

Swing Mechanism

The gear of the reducer and the swiveling support shall be indented jointed and the rotating gear shall be driven by constant displacement motor so as to drive the internal tooth of the swiveling support.

Braking: closed, concealed, wet type, spring loaded and brake, and oil pressure released spring brake;

Rotating Lock: Pilot-controlled pin shall be adopted to guarantee the upperworks can be completely locked when work finished or during transportation.

Free Wheelspin: By adopting free wheelspin, the upperworks shall free swing due to non-brake. When hoisting heavy objects, the free Wheelspin function shall automatically move to the correct position to prevent swinging of the object in case the centre of the boom and the centre of the heavy object are not in the same plane surface.

Rotating speed(R): 0~3.2r/min(Speed I)
0~1.6r/min (Speed II)

Rotating speed(K): 0~2.7r/min

A-frame

The A-frame is of telescopic type, which must be hoisted during operation. During transportation, the A-frame can be taken back to low down the height.

Upperworks

Driver's Cab

The novelty pattern sliding door of cab allows easy and safe opening and closing of the door; the large window, together with head light and rearview mirror, permits wider visual field. Air conditioner, mp3 player shall be installed. Seat, levers various electric switches are all designed according to ergonomics, which makes operation more comfortable.

Handrail: various levers, electric switches and ignition lock are installed onto the left and right handrails and auxiliary controlling cabinets. The handrails can be adjusted according to the adjustment of seat.

Seat: Suspended, multimode and multilevel adjustable seats with relief switch.

Air conditioning: Cold and warm wind, optimized tube and blast tuyere;

MP3 player: USB interface and radio function.

Dry powder fire extinguisher: capability 6kg.

Cover

The cover falls into left and right covers.

Left cover: upperworks handrail is at the front; the water charge inlet of the tank is at the top; slide access door is inside; the oil tank charging inlet and access doors are outside; there are silencing sponge on all access doors.

Right cover: 2 access doors at top for the replacement of the filter screen of the hydraulic oil tank; 4 access doors at outside; and the silencing sponge inside doors.

Counterweight

Basic counterweight: The weight is 17.5t, which is the sum of the pallet and the counterweight blocks. The left pallet is 3tX1, the left counterweight block is 3.6t X 2, and the right counterweight block is 3.6t X 2. The counterweight shall be removed during transportation.

Additional counterweight: the weight of the casting counterweight is 1.5t which shall be loaded onto the basic counterweight and shall be removed during transportation.

Under special conditions, the counterweight can be adopted for increasing the hoisting load after obtaining authorities.

Turntable

The turntable is steel structure including left and right walk platform and the main platform, which is welded. The left and right walk platform shall be connected with the main platform by bolts. The whole turntable shall be connected with track devices through rotating support. The main and auxiliary hoisting mechanism, the luffing mechanism, the hydraulic system, dynamical system, and the driver's cab are all installed on the turntable. The A-frame, operation equipment and the counterweight are connected to different position of the turntable separately.

Lowerworks

Chassis

All welded "I" shape structure, which is connected together with rotating bed turntable through bolts.

Track frame

All welded box-shaped structure, which is connected with the base through telescopic cylinder of track.

Pedal of track frame: Folding pedal is installed at the front of the **outer side** of the track frame; the fixed pedal is installed on the motor cover of the track frame.

Telescopic Cylinder of Track

Bi-functional cylinder is with 1300mm stroke, which achieve the expansion and shrinkage of the track through that of the cylinder.

Driving wheel

The material of the driving wheel is high strength alloy cast steel after surface treatment. The driving wheels are fixed to the traveling reducer.

Guide Wheel

The material of the guide wheel is high strength ally cast steel after surface treatment. The guide wheels are installed on the front of the track frame.

Thrust wheel

The material is high strength ally forged steel after surface treatment. 10 thrust wheels are installed on the surface of the bottom of the track frame for each side.

Upper guide wheel

The material is high strength ally forged steel after surface treatment. 3 thrust wheels are installed on the surface of the top of the track frame for each side.

Adjustment of tension of tracks

Manually controlled hydraulic jack to extend the guide wheel. By increasing or reducing the adjusting gasket to achieve perfect tensity.

Traveling

Both sides of the track frame have independent driving devices. The traveling hydraulic motor drives the driving wheel fixed on the reducer to enable straight traveling and turning. Travel speed: 0~1.39km/h (no-load, on horizontal and hard ground surface).

Track shoes

The material is high strength alloy forged steel after surface treatment. The width of the track shoe is 760mm and each track component is composed of 61 track shoes, which are installed onto the track frame.

Operation Device

Main Boom

Truss structure: the main chord pipe is made of high strength alloy steel and the central tube is made of carbon steel. The cross section of main boom is 1300mm X 1300mm and axial pin connection is used between sections.

Basic boom: the length of basic boom is 13m, which is composed of boom base 6.5m and boom tip 6.5m.

Boom inserts: it is composed of 3m X 1, 6m X 3 and 9m X 2, that is to say the length of the main boom is 13—52m.

Main boom guy rope: the length X number is respectively 6.35m X 2, 3m X 2, 6m X 6 and 9m X 4.

Jib

Truss structure: the main chord pipe is made of high strength alloy steel and the central tube is made of carbon steel. The cross section of jib is 550mm X 480mm and axial pin connection is used between sections.

Jib: the length of basic boom is 6.1m (the boom base and boom tip is respectively 3.05m). The length of boom inserts is 3.05m X 3, which means the length of the auxiliary is 6.1—15.25m.

Jib guy rope: Length X number is respectively: 1.77m X 1, 5.71m X 3, 14.14m X 1 and 13.15m X 1.

Maximum main boom + maximum jib: 43m+15.25m.

Boom extension

Welded structure, with a pulley at head connected to the main boom tip through pin.

Hook Block

50t hook block

30t hook block

15t hook block

5t ball hook block

Note: the above-mentioned equipments are the complete equipments. The detailed equipments shall be in accordance with the order.

Safety Device

Load Moment Indicator

There is an independent security operating system controlled by computer on the load moment indicator. It can automatically detect the mass hoisted by the crane and the angle of the boom and indicate the rated load, actual load, operating radius and angle of the boom.

Composition: host machine, monitor, angle sensor and force sensor etc.

Function: instantaneously display the rated load, actual load, operation radius, angle and height of the boom under the current situation of the crane. Automatically detect the dynamic data of the angle ultra-limitation and load ultra-limitation and alarm immediately and stop the operation.

Anti-overwinding device for main and auxiliary hooks

The limit switch and heavy punch fixed on the upper boom are used to prevent the hook from being lifted over high. When the hook is lifted to a certain height, the limit switch is activated so as to make the buzzer on the control board alarm by both electrical and hydraulic control and the hook lifting operation stop automatically. On this occasion, the hook overwinding could be prevented.

Anti-overloosening device for main and auxiliary hooks

It is composed of the motion trigger device fixed at inside of the drum and proximity switch. It shall send signal when the steel wire was loosened close to the last 3 circles and the electrical controlling system shall automatically stop the hooks and alarm through buzzer and monitor.

Commutator for assembling mode/operation mode

The anti-overwinding device, caging device of boom, A-frame alarming device, expansion device of track and moment limiter are all out of commission under the assembling mode so as to make it easier to install the crane.

Under the operation mode, all the safety devices can be operated.

A-frame Alarming Device

Under operation mode, the system shall alarm through buzzer and monitor in case the A-frame was not lifted to the right position.

Safety Device

Track expansion alarming device

Under the operation mode, the system shall alarm through buzzer and monitor in case the track was not extend to right position.

Caging Device for Boom

When the elevation of the boom is over 78°, the buzzer shall alarm and the boom shall be stopped. Synchronously, the lifting operation of swing drum is out of commission and only lowering operation is allowed. This protection function shall be controlled by both of the moment limiter and the two-stage control of travel switch.

When the angle of the boom is less than 30°, the buzzer shall alarm and the boom shall be stopped. Synchronously, the lowering operation of the swing drum is out of commission and only the lifting operation is allowed. This function shall be controlled by moment limiter.

Anti-retroversion device for boom

The anti-retroversion rod is made in nested steel pipe and spring structure fixed on the top of the lower boom of the main boom, which is equipped with the function of support through the spring pressure so as to prevent the main boom retroversion.

Rotating lock device

It is locked by hydraulic controlled power pin and it is used for locking the crane at the front and back orientation.

Drum Lock Device

Electrical controlled locking device is set to the main winch and luffing drums, which means it is essential to press the winding switch before the winding operation so as to prevent the mistaken motion caused by lever and to guarantee the safety when the winding is under non-operation mode.

Boom angle indicator

Pendulum-type angle indicator mounted at one side close to the driver's cab of the lower boom.

Hook Clamp

Each kind of lifting hook is equipped with baffle used to prevent the hoisting wire rope from coming off.

Acousto-optic Alarm

It can send acousto-optic alarm within 5 seconds after the engine started and during swing and traveling.

Gradienter

Electronic gradienter can indicate the inclining angle of the upperworks on the monitor of the control system.

Relief Switch

When the operator is not at seat or draws back the relief lever, the relief valve shall be closed and all the operations are out of commission so as to prevent misoperations.

Emergency stopping button

When emergency appears, press this button to cut of the electricity and stop all the operations.

Tricolor Load Alarming Light

The load alarming light includes 3 colors, green, yellow and red, which can display the instantaneous load synchronously. Namely, the green color means the load rate is under 90%, the yellow color means the load rate is between 90% to 100% and the red color means the load rate is over 100%, which is in overload situation.

Monitor System

Camera: 2 PCS, respectively monitor the rotating mechanism and the situation of the back portion for the complete appliance.

Monitor: the monitored images can be switched over through switches.

Anti-lightening stroke protection device

It includes grounding devices and surge-protect device, which can prevent the damage of the electronic components and the hurt of the staff from lightening.

Illuminator

Night lighting devices such as rotating illuminator, dipped light in front of the driver's cab, angle adjustable high beam and head lamp in driver's cab shall be set so as to improve safety for construction during night.

Rearview Mirror

The mirrors shall be respectively set at the right side of the driver's cab and the front handrail of the left cover.

Dimension

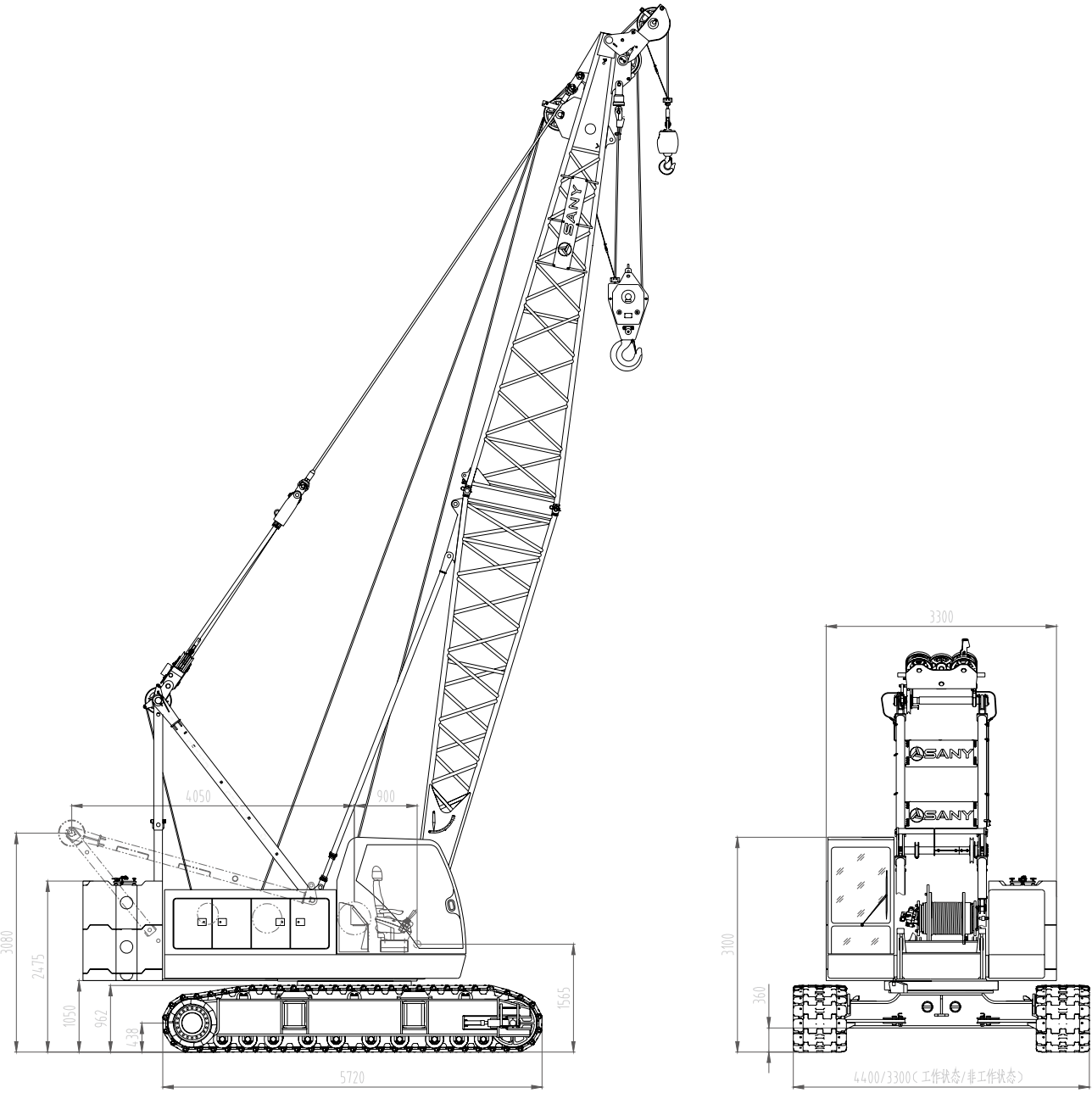

Main Dimensions for SCC500E Hydraulic Crawler Crane

Transportation Dimension of Main Parts

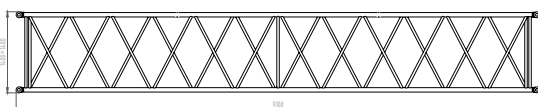
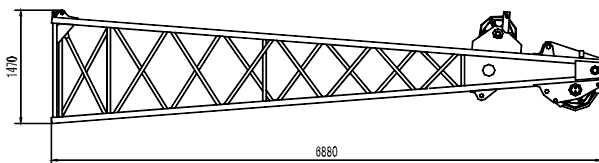
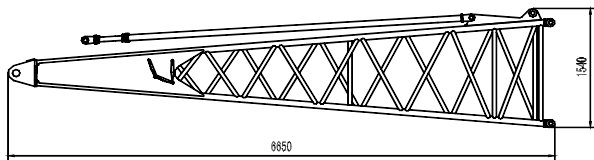
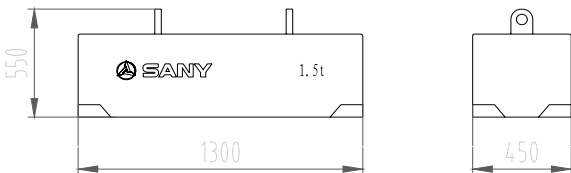
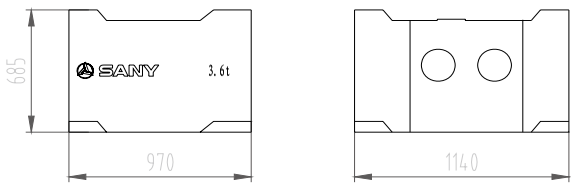
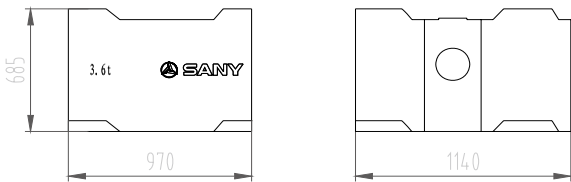
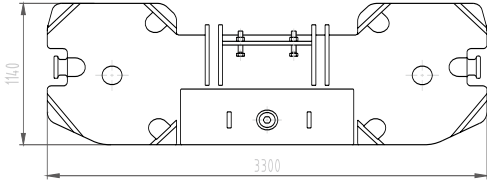
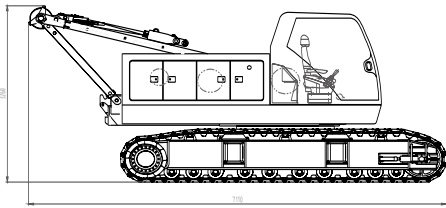

Mainbody ×1

Length	7.11m
Width	3.3m
Height	3.26m
Weight	30t

Pallet counterweight ×2

Length	3.3m
Width	1.14m
Height	0.79m
Weight	3.5t

Left counterweight block ×2

Length	0.97m
Width	1.14m
Height	0.685m
Weight	3.6t

Right Counterweight block ×2

Length	0.97m
Width	1.14m
Height	0.685m
Weight	3.6t

Additional counterweight block ×1

Length	0.97m
Width	1.14m
Height	0.55m
Weight	1.5t

Main boom base ×1

Length	6.65m
Width	1.54m
Height	1.40m
Weight	1.17t

Main boom tip ×1

Length	6.88m
Width	1.47m
Height	1.40m
Weight	1.1t

Boom insert 9m ×2

Length	9.1m
Width	1.4m
Height	1.4m
Weight	0.9t

Transportation Dimension of Main Parts

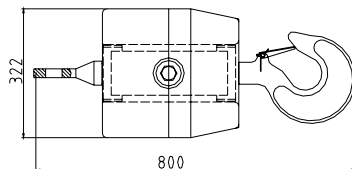
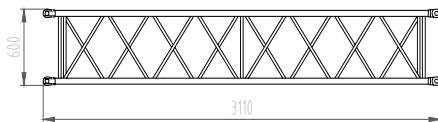
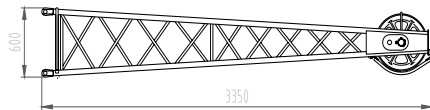
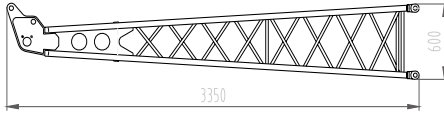
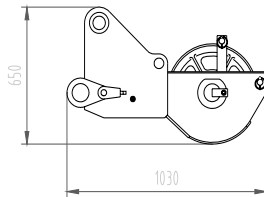
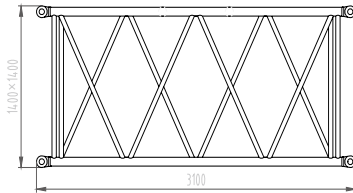
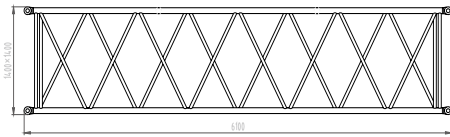

Boom insert 6m ×3

Length	6.1m
Width	1.4m
Height	1.4m
Weight	0.6t

Boom insert 3m ×1

Length	3.1m
Width	1.4m
Height	1.4m
Weight	0.4t

Boom extension ×1

Length	1.03m
Width	0.717m
Height	0.65m
Weight	0.2t

Jib tip ×1

Length	3.35m
Width	0.6m
Height	0.55m
Weight	0.2t

Jib base ×1

Length	3.35m
Width	0.6m
Height	0.55m
Weight	0.2t

Jib insert ×3

Length	3.11m
Width	0.6m
Height	0.55m
Weight	0.1t

5t Hook block ×1

Length	0.8m
Width	0.322m
Height	0.322m
Weight	0.2t

Transportation Dimension of Main Parts

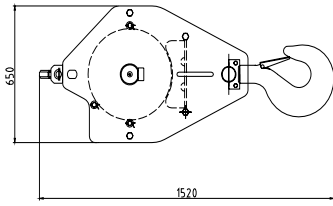

15t Hook block	×1
Length	1.52m
Width	0.65m
Height	0.311m
Weight	0.4t

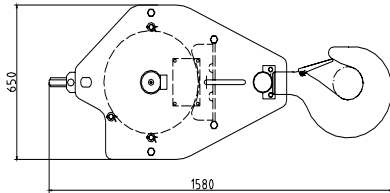

30t hook block	×1
Length	1.58m
Width	0.65m
Height	0.34m
Weight	0.5t

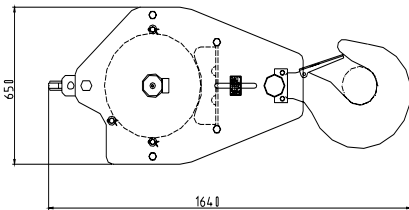

50t Hook block	×1
Length	1.65m
Width	0.65m
Height	0.392m
Weight	0.6t

Note:

- 1, The transportation dimension of main parts is sketch map, which was not drawn according to the rate. The dimension in the sketch is design value excluding package.
- 2, The weight is design value and there may be difference caused manufacture.

Schematic Diagram for Hoisting

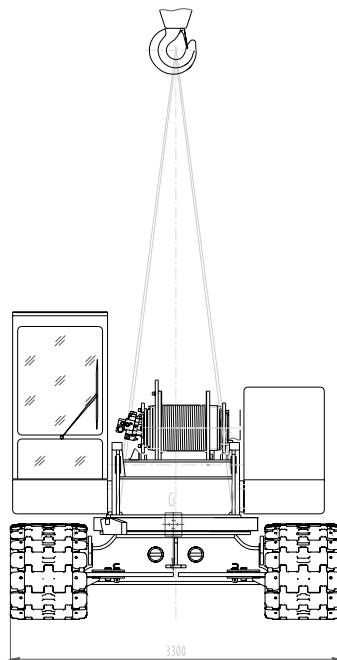
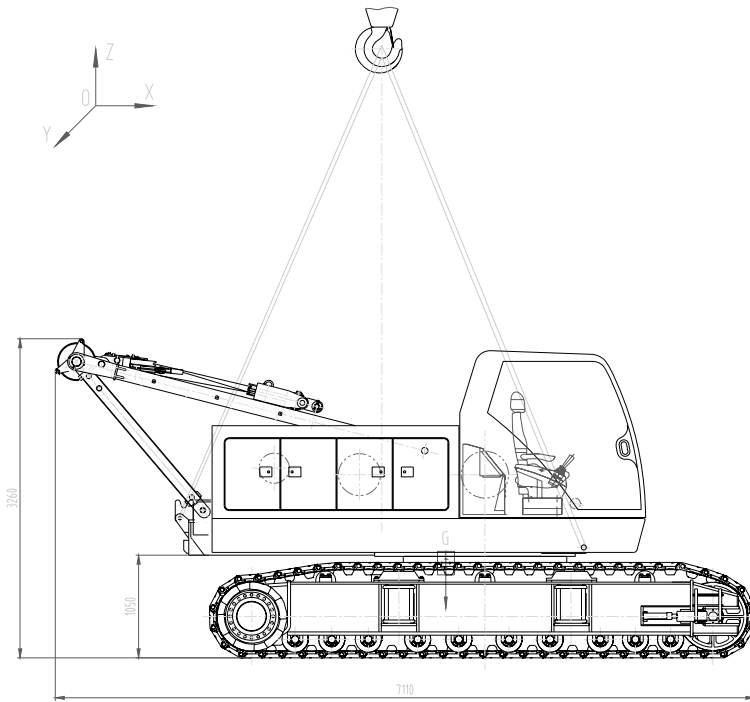

X=-390mm

Y=25mm

Z=950mm

Main Boom Combination

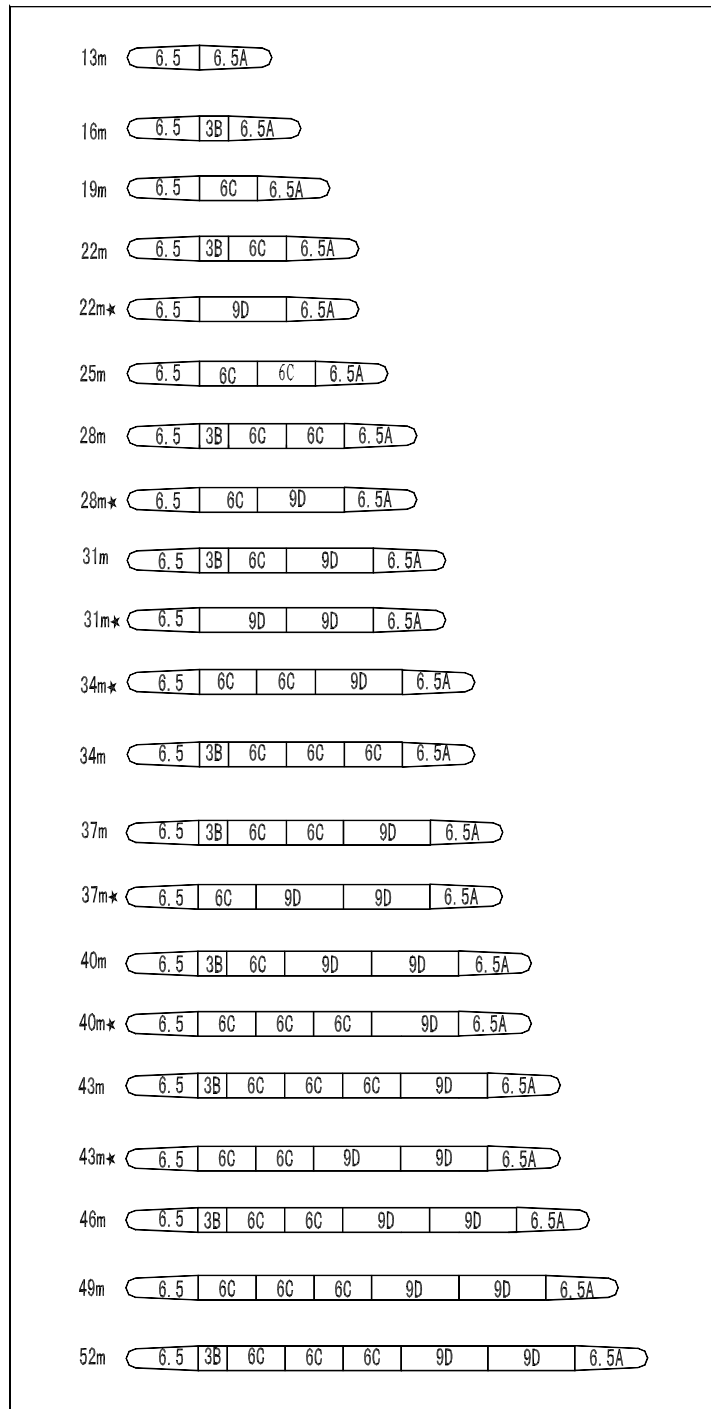

Note:

- 1、 The boom combination with ★ is preferential.
- 2、 The symbols A, B, C and D represents the main boom ropes matching the main boom. See the following table:

SN in Diagram	A	B	C	D
Length of the ropes (m)	6.35	3.0	6.0	9.0

Main Boom Range Diagram

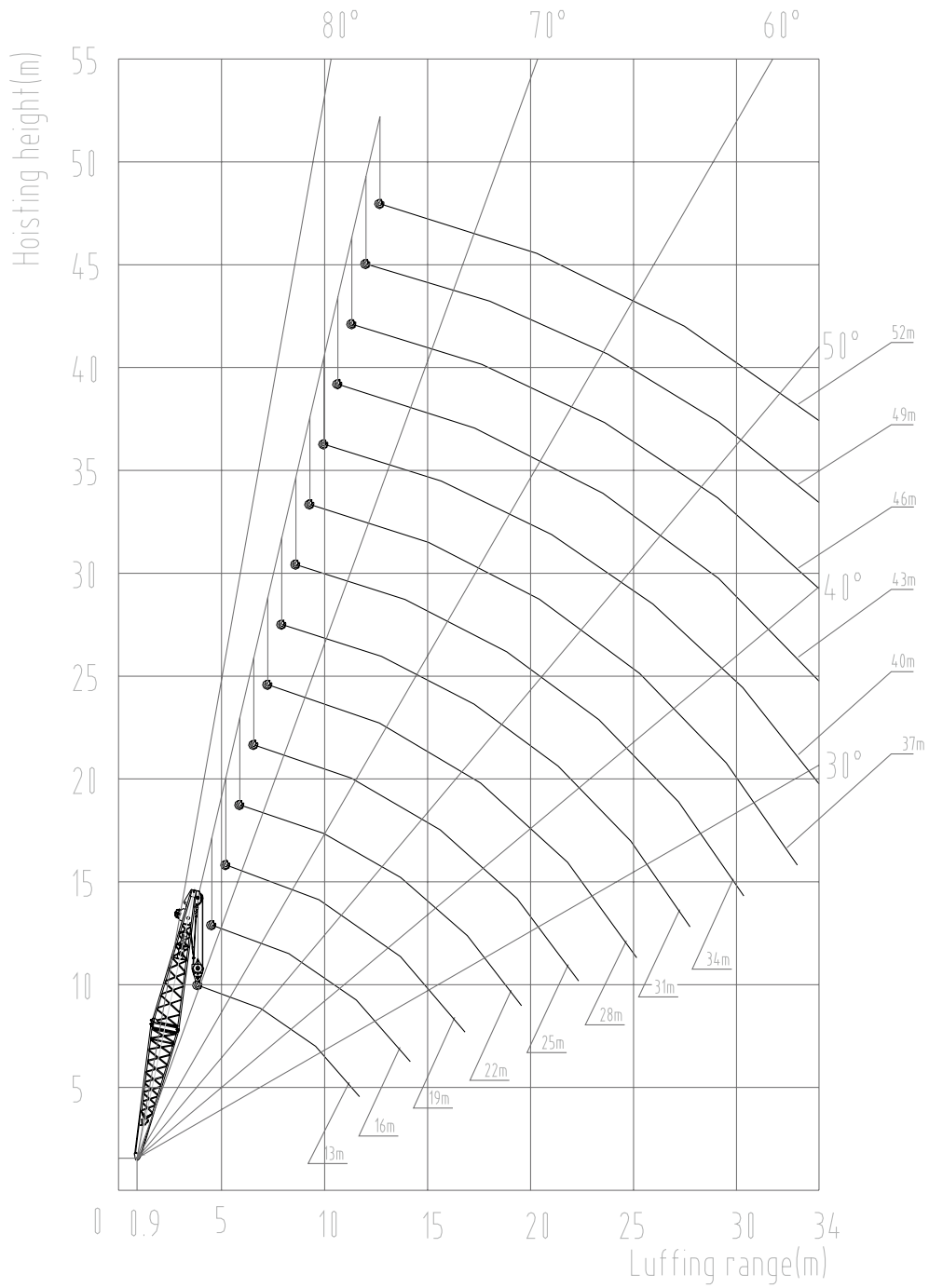

The Curve of Rising Without Jib

Main Boom Load Chart

Standard Load Chart(Counterweight:17.5t)

Unit:t

Radius (m)	Main Boom Length (m)													
	13	16	19	22	25	28	31	34	37	40	43	46	49	52
3.7	55													
4	48.34													
4.5	40.47	40.30												
5	34.75	34.58	34.45											
5.5	30.42	30.24	30.11	29.99										
6	27.02	26.85	26.71	26.58	25.82t									
7	22.03	21.85	21.71	21.58	21.40	21.27								
8	18.54	18.36	18.22	18.08	17.90	17.76	17.63	17.52						
9	15.96	15.78	15.64	15.50	15.32	15.18	15.04	14.92	14.85	14.25t				
10	13.98	13.79	13.65	13.52	13.33	13.19	13.06	12.92	12.84	12.71	12.63			
12	11.13	10.95	10.81	10.67	10.48	10.34	10.20	10.06	9.96	9.81	9.72	9.58	9.48	9.34
14		9.00	8.86	8.72	8.53	8.39	8.25	8.09	7.99	7.84	7.73	7.58	7.47	7.32
16			7.44	7.30	7.11	6.97	6.83	6.67	6.56	6.40	6.29	6.13	6.02	5.86
18				6.23	6.04	5.89	5.75	5.59	5.47	5.31	5.19	5.03	4.91	4.75
20					5.19	5.05	4.91	4.74	4.62	4.45	4.33	4.16	4.04	3.88
22					4.51	4.37	4.22	4.05	3.93	3.76	3.64	3.47	3.34	3.17
24						3.80	3.66	3.49	3.36	3.19	3.06	2.89	2.76	2.59
26							3.19	3.00	2.86	2.70	2.56	2.40	2.26	2.10
28								2.58	2.44	2.28	2.14	1.97	1.83	1.67
30								2.22	2.08	1.91	1.78	1.61	1.47	1.30
32									1.77	1.60	1.46	1.29	1.15	0.98
34										1.32	1.18	1.01	0.87	0.70

Main Boom Load Chart

Tone load chart(Counterweight 17.5t+1.5)

Unit:t

Radius (m)	Length of Main Boom (m)													
	13	16	19	22	25	28	31	34	37	40	43	46	49	52
3.7														
4														
4.5														
5														
5.5														
6														
7														
8								18.65						
9								15.90	15.83	15.21				
10								13.79	13.71	13.58	13.50			
12								10.76	10.66	10.52	10.43	10.29	10.19	10.05
14								8.69	8.58	8.43	8.33	8.18	8.07	7.92
16								7.18	7.07	6.91	6.80	6.64	6.53	6.38
18								6.04	5.92	5.76	5.64	5.48	5.36	5.17
20								5.14	5.02	4.85	4.73	4.57	4.45	4.23
22								4.41	4.29	4.12	4.00	3.83	3.71	3.47
24								3.82	3.69	3.52	3.40	3.23	3.10	2.85
26								3.31	3.17	3.01	2.87	2.71	2.57	2.32
28								2.86	2.73	2.56	2.43	2.26	2.12	1.88
30								2.48	2.35	2.18	2.04	1.88	1.74	1.50
32									2.02	1.85	1.71	1.54	1.40	1.17
34										1.56	1.42	1.25	1.11	0.88

Note—Rated load of the crane

- 1、The rated loads in the table represent the values when slowly and smoothly hoisting a weight on a horizontal and hardy soil surface under non-traveling hoisting working state.
- 2、The rated loads in the table were calculated under the condition that the wind speed was 9.8m/s and according to 75% of the tilting load.
- 3、The rated load includes the mass of hook block and other comments. Actual hoisting weight is the value of rated load in the table deducing weight of all hoisting implements such as hoisting hook block etc. (for 50t hook block, mass 0.6t, for 15t hook block, mass 0.4t, for 30t hook block, mass 0.5t)
- 4、When installing jib or extension boom, the rated load includes masses of main and auxiliary hook blocks and the value listed in the following table. The actual load-hoisting capacity of the crane is the value in table 2.2 deducing the mass listed in the following table as well as masses of main and auxiliary hook blocks, but it will not work if the residual value is below 0.8t.

Main Boom Load Chart

Jib Length (m)	6.10	9.15	12.20	15.25	Extension Boom
Deducted Mass (t)	0.70	0.85	1.00	1.15	0.20

5、The length of available main boom for installing jibs is 22~43m. The maximum length of the main boom of the jibs is 49m.

6、When hoisting, the track frame of the crane must be at expansion state.

7、The relation between multiplying power of wire rope and maximum rated load and mass of hook block us listed in the following table.

Tonnage of hook block (t)	Mass of hook block (t)	Maximum rated total load (t)								
		9 multiplying power	8 multiplying power	7 multiplying power	6 multiplying power	5 multiplying power	4 multiplying power	3 multiplying power	2 multiplying power	1 multiplying power
50	0.6	55.0	44.8	39.9	34.2	28.5	22.8	17.1	11.4	5.7
30	0.5				30.0	28.5	22.8	17.1	11.4	5.7
15	0.4							15.0	11.4	5.7
5	0.2									5.0

8、All values in the load table apply to 360°swing.

9、The counterweight (17t+1.5t) is an optional operation mode, but not standard operation mode. The length of main boom for the allowed additional counterweight is 34~52m.

Jib Range Diagram

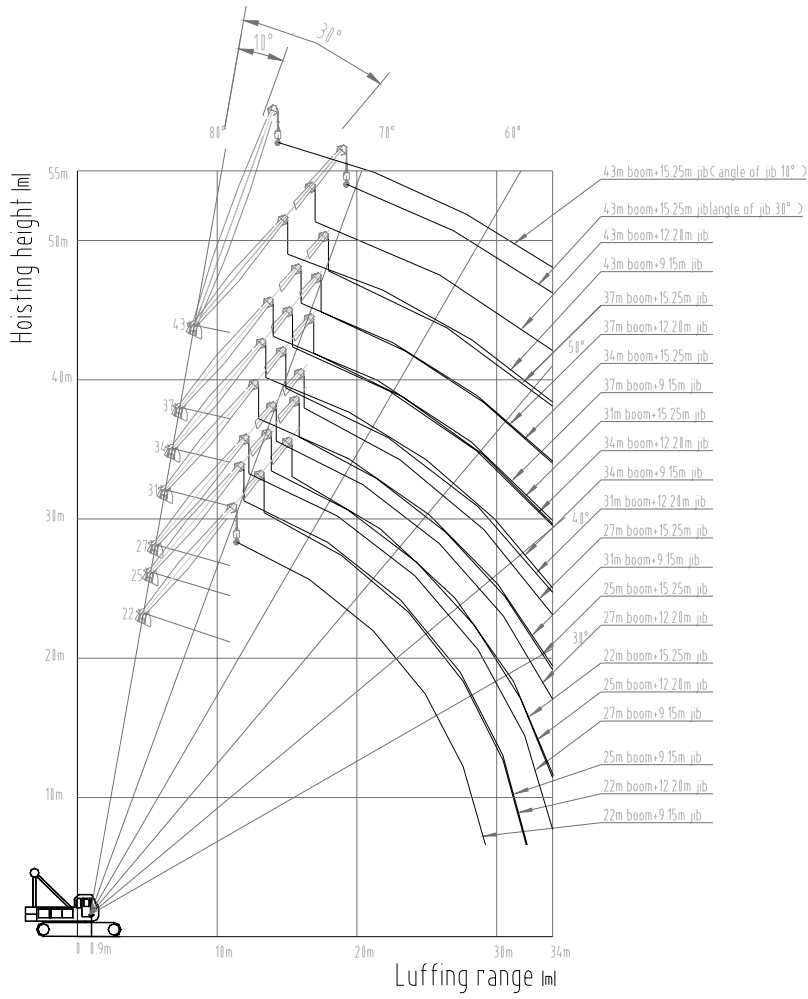

Jib Combination

Jib Length (m)	Section Combination		Main Boom Length(m)	Angle between Main Boom and Jib
	Lateral extension boom tip and base	Boom insert		
6.10	One each	—	22~43	10°, 30°
9.15	One each	1	22~43	10°, 30°
12.2	One each	2	22~43	10°, 30°
15.25	One each	3	22~43	10°, 30°

Jib Load Chart

Main Boom 22m								
Jib Length (m)	6.10		9.15		12.2		15.25	
Angle of Jib radius (m)	10°	30°	10°	30°	10°	30°	10°	30°
8.0	5.00	9.8m × 5.00t	9.2m × 5.00t					
10.0	5.00	5.00	5.00		10.3m × 4.00t		11.4m × 3.20t	
12.0	5.00	5.00	5.00	4.65	4.00		3.2	
14.0	5.00	15.4m × 5.00t	5.00	4.30	4.00	3.65	3.2	
16.0	5.00	4.90	5.00	4.05	4.00	3.45	16.8m × 3.20t	3.05
18.0	19.5m × 5.00t	4.65	19.7m × 5.00t	3.85	19.8m × 3.85t	3.25	3.15	2.90
20.0	4.80	21.7m × 4.30t	4.85	3.65	3.75	3.10	3.05	2.75
22.0	4.20	4.20	4.25	3.50	3.65	2.95	2.95	2.60
24.0	3.70	3.75	3.75	3.35	3.50	2.80	2.90	2.45
26.0	3.30	3.35	3.35	27.2m × 3.20t	3.40	2.70	2.80	2.35
28.0	26.1m × 3.30t	26.5m × 3.25t	3.05	3.05	3.05	2.60	2.70	2.25
30.0			29.0m × 2.90t	29.0m × 3.85t	2.75	2.55	2.60	2.15
32.0					31.8m × 2.50t	2.50	2.50	2.10
34.0						32.6m × 2.50t	2.30	2.05

Main Boom 25m								
Jib Length (m)	6.10		9.15		12.2		15.25	
Angle of Jib radius (m)	10°	30°	10°	30°	10°	30°	10°	30°
8.0	8.6m × 5.00t		9.8m × 5.00t		10.9m × 4.00t			
10.0	5.00	10.4m × 5.00t	5.00		4.00			
12.0	5.00	5.00	5.00	12.5m × 4.65t	4.00		12.1m × 3.65t	
14.0	5.00	5.00	5.00	4.40	4.00	14.5m × 3.65t	3.20	
16.0	5.00	16.5m × 5.00t	5.00	4.15	3.85	3.50	16.5m × 3.20t	16.6m × 3.05t
18.0	19.3m × 5.00t	4.80	19.5m × 5.00t	3.90	3.75	3.35	3.15	2.95
20.0	4.70	20.6m × 4.55t	4.80	3.70	3.65	3.20	3.05	2.80
22.0	4.10	4.15	4.20	3.55	3.50	3.05	2.95	2.65
24.0	3.65	3.65	3.70	3.40	3.30	2.90	2.90	2.55
26.0	3.25	3.25	3.30	3.30	2.95	2.80	2.80	2.40
28.0	2.90	2.90	2.95	3.00	2.65	2.70	2.70	2.30
30.0	28.7m × 2.80t	29.1m × 2.75t	26.5	2.70	2.40	31.4m × 2.60t	2.65	2.20
32.0			31.6m × 2.45t	2.40	2.20	2.40	2.45	2.20
34.0						2.25	2.20	2.10

Jib load chart

Main Boom 28m								
Jib Length (m)	6.10		9.15		12.2		15.25	
Angle of Jib Radius (m)	10°	30°	10°	30°	10°	30°	10°	30°
8.0	9.3m× 5.00t							
10.0	5.00	11.1m× 5.00t	10.4m× 5.00t		11.6m× 4.00t			
12.0	5.00	5.00	5.00	13.1m× 4.65t	4.00		12.7m× 3.20t	
14.0	5.00	5.00	5.00	4.50	4.00	15.1m× 3.05t	3.20	
16.0	5.00	17.7m× 5.00t	5.00	4.25	4.00	3.60	16.8m× 3.20t	17.2m× 3.05t
18.0	19.0m× 5.00t	19.8m× 4.75t	19.2m× 5.00t	4.05	3.85	3.45	3.15	3.00
20.0	4.60	4.70	4.70	3.85	3.75	3.30	3.05	2.85
22.0	4.00	4.10	4.10	3.70	3.65	3.15	2.95	2.75
24.0	3.50	3.60	3.60	24.8m× 3.50t	3.50	3.00	2.90	2.60
26.0	3.10	3.15	3.20	3.25	3.20	2.85	2.80	2.50
28.0	2.75	2.80	2.85	2.90	2.85	2.75	2.70	2.40
30.0	2.45	2.50	2.55	2.60	2.55	2.65	2.60	2.30
32.0	31.3m× 2.30t	31.7m× 2.30t	2.30	2.30	2.30	2.40	2.35	2.20
34.0			2.05	2.10	2.10	2.15	2.10	2.15

Main Boom 31m								
Jib Length (m)	6.10		9.15		12.2		15.25	
Angle of Jib Radius (m)	10°	30°	10°	30°	10°	30°	10°	30°
8.0	9.9m× 5.00t							
10.0	5.00	11.7m× 5.00t	11.0m× 5.00t					
12.0	5.00	5.00	5.00	13.7m× 4.65t	12.2m× 4.00t		13.3m× 3.20t	
14.0	5.00	5.00	5.00	4.60	4.00		3.20	
16.0	5.00	5.00	5.00	4.35	4.00	3.65	16.8m× 3.20t	
18.0	18.8m× 5.00t	19.0m× 5.00t	19.0m× 5.00t	4.15	3.85	3.50	3.15	3.05
20.0	4.50	4.65	4.65	3.95	3.75	3.35	3.05	2.95
22.0	3.95	4.00	4.00	23.6m× 3.70t	3.65	3.20	2.95	2.80
24.0	3.45	3.50	3.50	3.60	3.50	3.10	2.90	2.65
26.0	3.05	3.10	3.10	3.20	3.15	2.95	2.80	2.55
28.0	2.70	2.75	2.75	2.85	2.85	2.85	2.75	2.45
30.0	2.40	2.45	2.45	2.55	2.50	2.60	2.50	2.35
32.0	2.15	2.20	2.20	2.25	2.25	2.30	2.25	2.25
34.0	33.9m× 1.90t	1.95	1.95	2.00	2.00	2.10	2.05	2.15

Jib load chart

Main Boom 34m								
Jib Length (m)	6.10		9.15		12.2		15.25	
Angle of Jib Radius (m)	10°	30°	10°	30°	10°	30°	10°	30°
8.0								
10.0	10.5m × 5.00t		11.7m × 5.00t					
12.0	5.00	12.3m × 5.00t	5.00		12.8m × 4.00t		13.9m × 3.20t	
14.0	5.00	5.00	5.00	14.4m × 4.60t	4.00		3.20	
16.0	5.00	5.00	5.00	4.45	4.00	16.4m × 3.65t	16.8m × 3.20t	
18.0	18.6m × 5.00t	18.8m × 5.00t	18.8m × 5.00t	4.25	3.85	3.55	3.15	18.4m × 3.05t
20.0	4.45	4.60	4.55	4.05	3.75	3.40	3.05	2.90
22.0	3.75	3.95	3.95	23.0m × 3.80t	3.65	3.30	2.95	2.80
24.0	3.40	3.45	3.45	3.55	3.50	3.10	2.90	2.70
26.0	2.95	3.05	3.05	3.15	3.05	27.7m × 2.90t	2.80	2.60
28.0	2.60	2.65	2.70	2.80	2.70	2.85	2.75	2.50
30.0	2.30	2.35	2.40	2.45	2.40	2.55	2.45	2.45
32.0	2.05	2.05	2.10	2.20	2.15	2.25	2.20	2.30
34.0	1.80	1.85	1.85	1.95	1.90	2.00	1.95	2.05

Main Boom 37m								
Jib Length (m)	6.10		9.15		12.2		15.25	
Angle of Jib Radius (m)	10°	30°	10°	30°	10°	30°	10°	30°
8.0								
10.0	11.1m × 5.00t							
12.0	5.00	12.9m × 5.00t	12.3m × 5.00t		13.4m × 4.00t			
14.0	5.00	5.00	5.00	15.0m × 4.60t	4.00		14.6m × 3.20t	
16.0	5.00	5.00	5.00	4.50	4.00	17.0m × 3.65t	16.8m × 3.20t	
18.0	18.4m × 5.00t	18.6m × 5.00t	18.6m × 5.00t	4.30	3.85	3.60	3.15	19.1m × 3.05t
20.0	4.40	4.50	4.45	4.15	3.75	3.45	3.05	2.95
22.0	3.80	3.90	3.85	4.00	3.65	3.30	2.95	2.85
24.0	3.30	3.40	3.35	3.50	3.40	3.20	2.90	2.75
26.0	2.85	2.95	2.95	3.10	3.00	26.6m × 3.05t	2.80	2.65
28.0	2.50	2.60	2.60	2.70	2.60	2.80	2.65	2.60
30.0	2.20	2.30	2.30	2.40	2.30	2.45	2.35	2.50
32.0	1.90	2.00	2.00	2.10	2.05	2.20	2.10	2.20
34.0	1.65	1.75	1.75	1.85	1.80	1.90	1.85	2.00

Jib load chart

Main Boom 40m								
Jib Length (m)	6.10		9.15		12.2		15.25	
Angle of Jib Radius (m)	10°	30°	10°	30°	10°	30°	10°	30°
8.0								
10.0	11.8m× 5.00t							
12.0	5.00	13.6m× 5.00t	12.9m× 5.00t					
14.0	5.00	5.00	5.00	15.6m× 4.60t	14.8m× 4.00t		15.2m× 3.20t	
16.0	5.00	5.00	5.00	4.55	4.00		16.8m× 3.20t	
18.0	18.1m× 5.00t	18.5m× 5.00t	18.4m× 5.00t	4.35	3.85	3.65	3.15	19.7m× 3.05t
20.0	4.30	4.45	4.30	21.6m× 4.10t	3.75	3.50	3.05	3.00
22.0	3.70	3.80	3.75	3.95	3.65	3.40	2.95	2.90
24.0	3.20	3.30	3.25	3.45	3.30	25.4m× 3.20t	2.90	2.80
26.0	2.75	2.85	2.85	3.00	2.90	3.10	2.80	2.70
28.0	2.40	2.45	2.45	2.60	2.55	2.70	2.60	2.60
30.0	2.10	2.15	2.15	2.30	2.20	2.40	2.25	2.45
32.0	1.80	1.85	1.85	2.00	1.90	2.10	1.95	2.20
34.0	1.55	1.60	1.60	1.70	1.65	1.80	1.70	1.90

Main boom 43m								
Jib Length (m)	6.10		9.15		12.2		15.25	
Angle of jib Radius (m)	10°	30°	10°	30°	10°	30°	10°	30°
8.0								
10.0								
12.0	12.4m× 5.00t		13.5m×5.00t					
14.0	5.00	14.2m×5.00t	5.00		14.7m×4.00t		15.8m×3.20t	
16.0	5.00	5.00	5.00	16.2m×4.60t	4.00		16.8m×3.20t	
18.0	5.00	18.4m×5.00t	18.3m×5.00t	4.45	3.85	19.3m×3.65t	3.15	
20.0	4.25	4.40	4.30	21.2m×4.20t	3.75	3.60	3.05	20.3m×3.05t
22.0	3.65	3.75	3.70	3.95	3.65	3.45	2.95	2.95
24.0	3.15	3.25	3.20	3.40	3.20	24.8m×3.30t	2.90	2.85
26.0	2.70	2.80	2.80	2.95	2.80	3.00	2.80	2.75
28.0	2.35	2.40	2.40	2.55	2.45	2.65	2.50	2.70
30.0	2.00	2.10	2.10	2.25	2.10	2.30	2.15	2.40
32.0	1.70	1.80	1.80	1.95	1.80	2.00	1.85	2.10
34.0	1.45	1.50	1.55	1.65	1.55	1.70	1.60	1.90