

Hydraulic Crawler Crane

BMS

1000

Max. Lifting Capacity: 100 t x 3.8 m

Max. Crane Boom Length: 62.6 m

Model : BMS1000

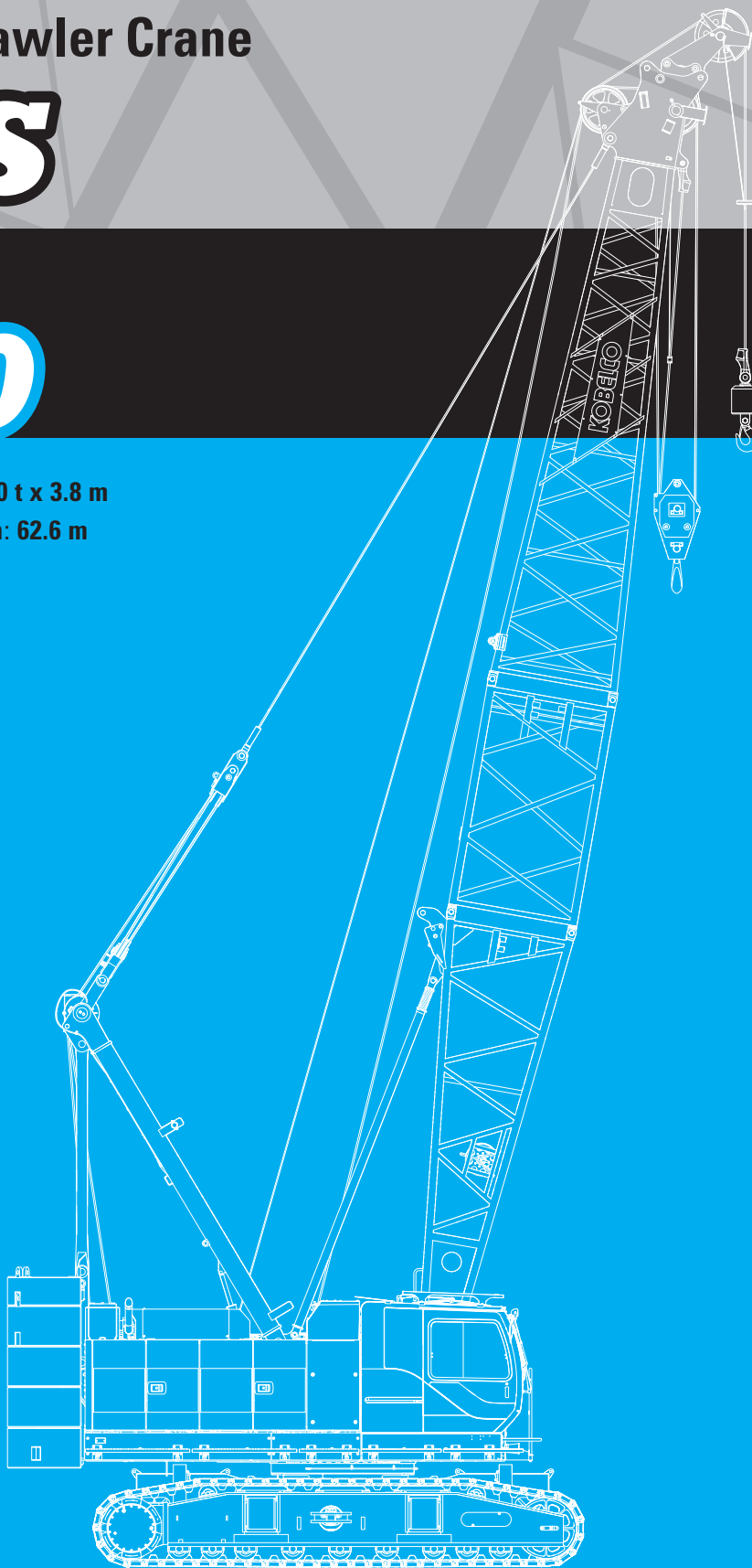

KOBELCO



BMS1000 CONTENTS

3	SPECIFICATIONS
5	GENERAL DIMENSIONS
6	BOOM AND JIB ARRANGEMENTS
7	WORKING RANGES
8	SUPPLEMENTAL DATA
9	LIFTING CAPACITIES
10	SUPPLEMENTAL DATA FOR CLAMSHELL
11	LIFTING CAPACITIES
12	SUPPLEMENTAL DATA FOR REDUCED WEIGHTS
13	LIFTING CAPACITIES
14	SUPPLEMENTAL DATA FOR BARGE
15	LIFTING CAPACITIES
16	TRANSPORTATION PLAN
17	PARTS AND ATTACHMENTS

SPECIFICATIONS



Power Plant

Model: HINO P11C-VH

Type: 4 cycle, water-cooled, vertical in-line 6, direct injection, turbo-charger, intercooler.

Displacement: 10.520 liters

Rated power: 271 kW / 1,850 min⁻¹

Max. Torque: 1,470 N·m / 1,400 min⁻¹

Cooling System: Water-cooled

Starter: 24 V- 6 kw

Radiator: Corrugated type core, thermostatically controlled

Air cleaner: Dry type with replaceable paper element

Throttle: Twist grip type hand throttle, electrically actuated

Fuel filter: Replaceable paper element

Batteries: Two 12 V x 136 Ah/5HR capacity batteries, series connected

Fuel tank capacity: 400 liters



Hydraulic System

Main pumps: 3 variable displacement piston pumps

Control: Full-flow hydraulic control system for infinitely variable pressure to all winches, propel and swing. Controls respond instantly to the touch, delivering smooth function operation.

Cooling: Oil-to-air heat exchanger (plate-fin type)

Filtration: Full-flow and bypass type with replaceable element

Max. relief valve pressure:

Load hoist, boom hoist and propel system: 31.9 Mpa

Swing system: 27.5 MPa

Control system: 5.4 MPa

Hydraulic Tank Capacity: 440 liters



Boom Hoisting System

Powered by a hydraulic motor through a planetary reducer.

Brake: A spring-set, hydraulically released multiple-disc brake is mounted on the boom hoist motor and operated through a counter-balance valve.

Drum Lock: External ratchet for locking drum

Drum: Single drum, grooved for 20 mm dia. wire rope

Line Speed: Single line on first drum layer

Hoisting/Lowering: 50 to 3 m/min

Boom hoisting/lowering: 20 mm x 140 m

Boom guy line: 34 mm

Boom backstops: Required for all boom length



Load Hoisting System

Front and rear drums for load hoist powered by a hydraulic variable plunger motors, driven through planetary reducers.

Positive & Negative Brake: Forced-circulation oil-cooled wet-type multi-disc brake, each using positive and negative actuation.

The drums are manually locked by the control cable. Both positive and negative brake systems are available in lever neutral position.

Drum Lock: External ratchet for locking drum

Drums:

Front Drums: 616 mm P.C.D x 620 mm wide drum, grooved for 28 mm wire rope. Rope capacity is 200 m working length and 284 m storage length.

Rear Drum: 616 mm P.C.D x 620 mm grooved for 28 mm wire rope. Rope capacity is 130 m working length and 284 m storage length.

Diameter of wire rope

Main winch: 28 mm x 200 m

Aux. winch: 28 mm x 130 m

Third winch: 26 mm x 190 m

Line Speed*:

Hoisting/lowering: 110 to 3 m/min

Line Pull:

Max. Line Pull* : 252 kN {25.7 tf}

(Referential Performance)

Rated Line Pull: 132 kN {13.5 tf}

*Single line on first drum layer



Swing System

Swing unit is powered by hydraulic motor driving spur gears through planetary reducers, the swing system provides 360° rotation.

Swing parking brakes: A spring-set, hydraulically released multiple-disc brake is mounted on swing motor.

Swing circle: Single-row ball bearing with an integral internally cut swing gear.

Swing lock: Manually, four position lock for transportation

Swing Speed: 3.2 min⁻¹



Upper Structure

Torsion-free precision machined upper frame. All components are located clearly and service friendly. Engine will with low noise level.

Counterweight: 37.1 ton



Cab & Control

Totally enclosed, full vision cab with safety glass, fully adjustable, high backed seat with a headrest and armrests, and intermittent wiper and window washer (skylight and front window).

Cab fittings:

Air conditioner, convenient compartment (for tool), cup holder, cigarette lighter, sun visor, roof blind, tinted glass, floor mat, footrest, and shoe tray



Lower Structure

Steel-welded carbody with axles. Crawler assemblies can be hydraulically extended for wide-track operation or retracted for transportation. Crawler belt tension is maintained by hydraulic jack force on the track-adjusting bearing block.

Carbodyweight: 14.6 ton

Crawler drive: Independent hydraulic propel drive is built into each crawler side frame. Each drive consists of a hydraulic motor propelling a driving tumbler through a planetary gear box. Hydraulic motor and gear box are built into the crawler side frame within the shoe width.

Crawler brakes: Spring-set, hydraulically released parking brakes are built into each propel drive.

Steering mechanism: A hydraulic propel system provides both skid steering (driving one track only) and counter-rotating steering (driving each track in opposite directions).

Track rollers: Sealed track rollers for maintenance-free operation.

Shoe (flat): 900 mm wide each crawler

Max. gradeability: 30 %



Weight

Including upper and lower machine, 37.1 ton counterweight and 14.6 ton carbody weight, basic boom hook, and other accessories.

Weight: 107.0 ton

Ground pressure: 109 kPa



Attachment

Boom & Jib:

Welded lattice construction using tubular, high-tensile steel chords with pin connection between sections.

Boom length

	Min. Length	Max. Length
Crane Boom	13.8 m	62.6 m

Main Specifications (Model: BMS1000)

Crane Boom	
Max. Lifting Capacity	100 t x 3.8 m
Max. Length	62.6 m
Main & Aux. Winch	
Max. Line Speed (1st layer)	110 m/min
Rated Line Pull (Single line)	132 kN {13.5 tf}
Wire Rope Diameter	28 mm
Wire Rope Length	200 m (Main), 130 m (Aux.)
Brake Type (free fall)	Wet-type multiple disc brake (Standard)
Working Speed	
Swing Speed	3.2 min ⁻¹ {rpm}
Travel Speed	1.4/1.0 km/h
Power Plant	
Model	HINO P11C-VH
Engine Output	271 kW / 1,850 min ⁻¹
Fuel Tank	400 liters

Hydraulic System	
Main Pumps	3 variable displacement
Max. Pressure	31.9 MPa {325 kgf/cm ² }
Hydraulic Tank Capacity	440 liters
Self-Removal Device	
	NA
Weight	
Operating Weight	107 t ^{*1}
Ground Pressure	109 kPa
Counterweight	37,140 kg
Transport Weight	31,000 kg ^{*2}

Units are SI units. { } indicates conventional units.

Line speeds in table are for light loads. Line speed varies with load.

*1 Including upper and lower machine, 37.1 ton counterweight, 14.6 ton carbody weight, basic boom, hook, and other accessories.

*2 Base machine with boom base, gantry, and wire ropes (front/rear/third/boom hoist)

GENERAL DIMENSIONS

(Unit: mm)

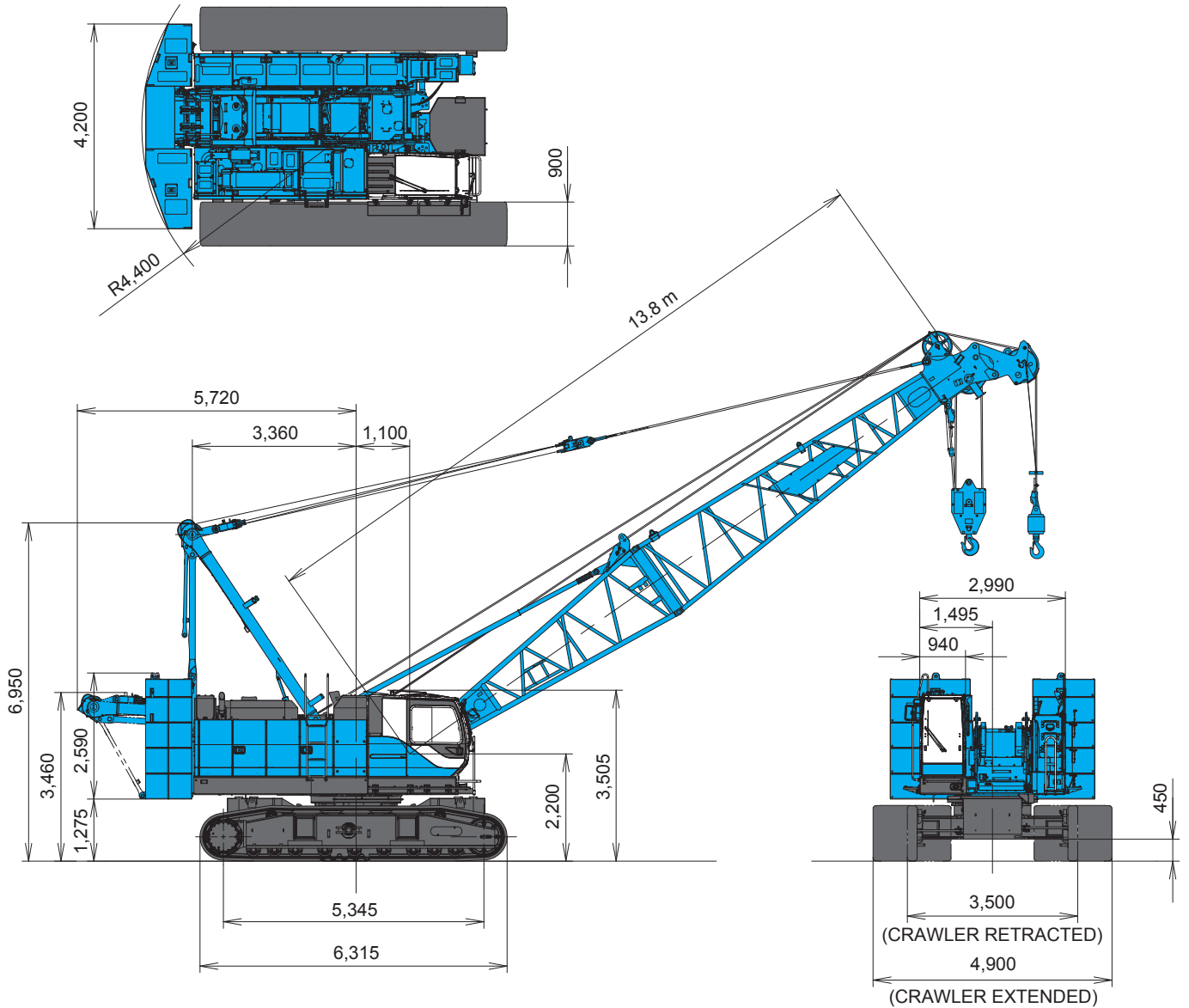

This catalog may contain photographs of machines with specifications, attachments and optional equipment.

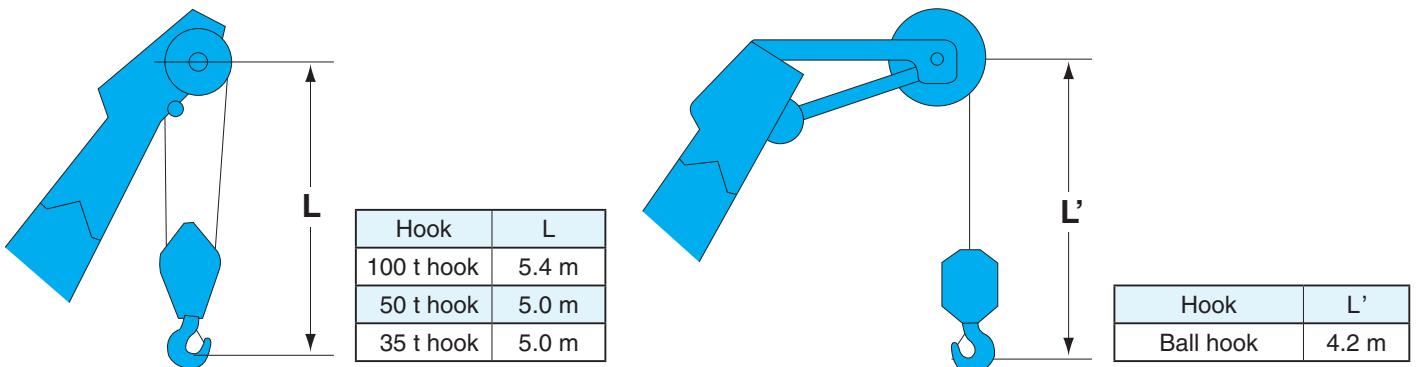

Limit of Hook Lifting





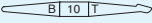
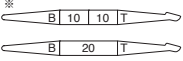
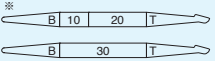
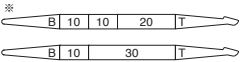
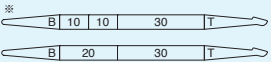
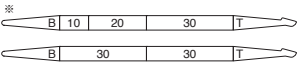
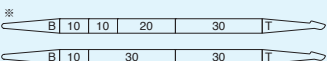
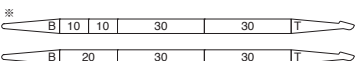

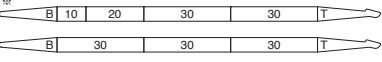
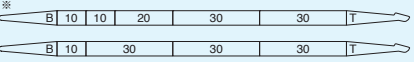
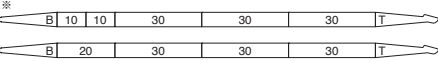
BOOM AND JIB ARRANGEMENTS

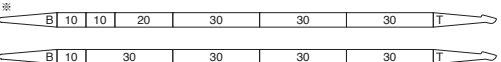
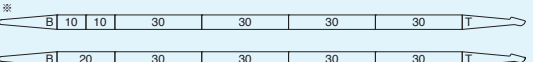
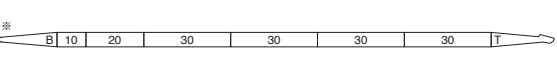
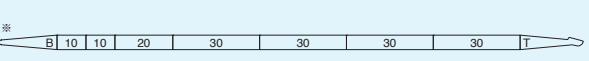
Crane Boom Arrangements

Boom length m (ft)	Boom arrangement
13.8 (45)	
16.9 (55)	
19.9 (65)	
23.0 (75)	
26.0 (85)	
29.1 (95)	
32.1 (105)	
35.2 (115)	
38.2 (125)	

Boom length m (ft)	Boom arrangement
41.2 (135)	
44.3 (145)	
47.3 (155)	
50.4 (165)	
53.4 (175)	
56.5 (185)	
59.5 (195)	
62.6 (205)	

Symbol	Boom Length	Remarks
	6.2 m	Boom Base
	7.6 m	Boom Top
	3.0 m	Insert Boom
	6.1 m	Insert Boom
	9.1 m	Insert Boom

※ mark shows the standard boom arrangement which enables each boom length of less than that boom length to be configured.

WORKING RANGES

Crane Boom

Unit : m

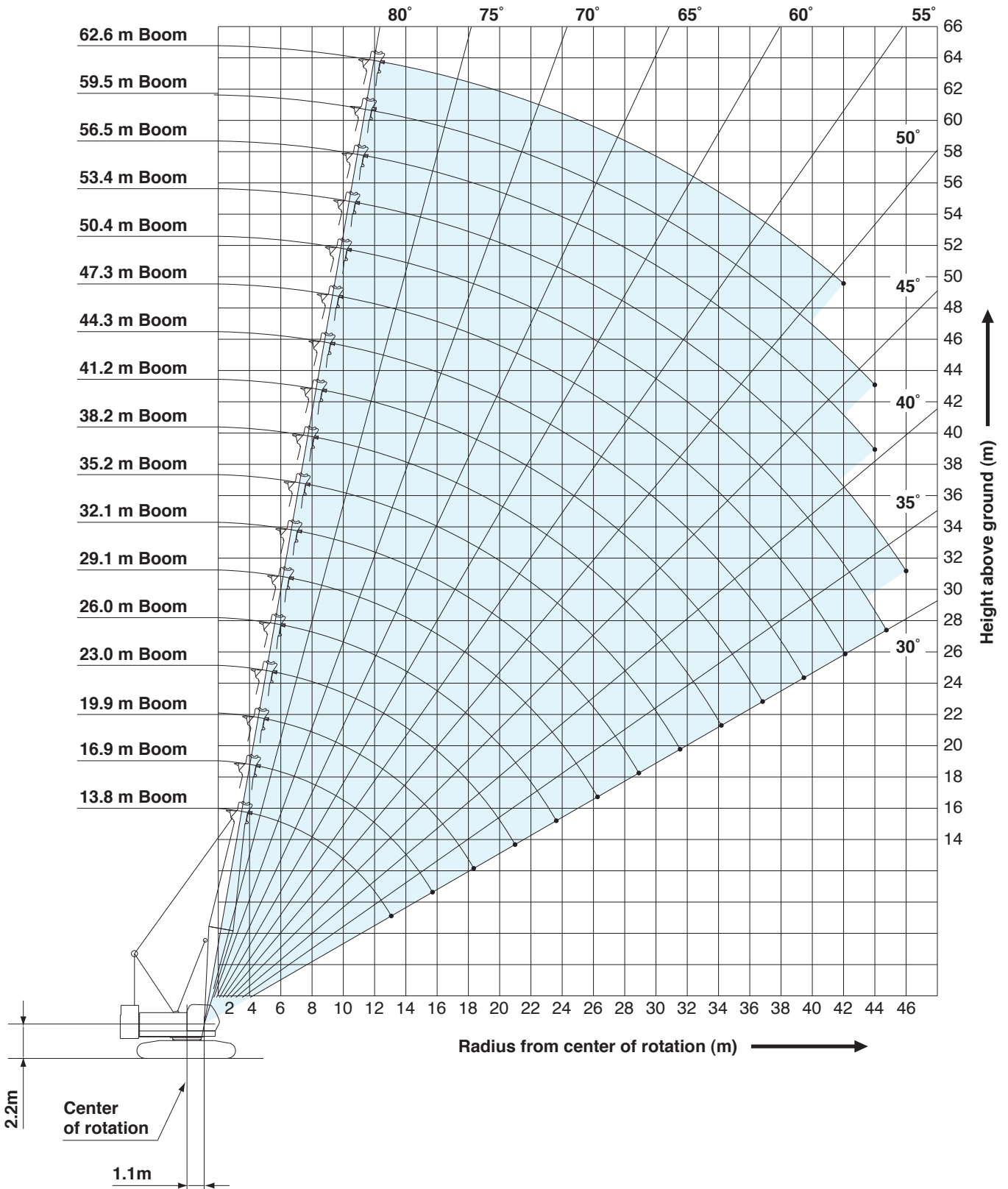

- Ratings according to Japanese construction codes for mobile cranes.
- Operating radius is the horizontal distance from centerline of rotation to a vertical line through the center of gravity of the load.
- Deduct weight of hook block(s), slings and all other load handling accessories from main boom ratings shown.
- Ratings shown are based on freely suspended loads and make no allowance for such factors as wind effect on lifted load, ground conditions, out-of-level, operating speeds or any other condition that could be detrimental to the safe operation of this equipment. The operator, therefore, has the responsibility to judge the existing conditions and reduce lifted loads and operating speeds accordingly.
- Ratings are for operation on a firm and level surface, up to 1% gradient.
- At radii and boom lengths where no ratings are shown on chart, operation is not intended nor approved.
- Boom inserts and guy lines must be arranged as shown in the "operator's manual".
- Boom hoist reeving is 10 part line.
- Gantry must be in raised position for all conditions.
- Boom backstops are required for all boom lengths.
- The boom should be erected over the front of the crawlers, not laterally.
- Ratings inside of boxes are limited by strength of materials.
- The minimum rated load is 1.5 (ton).
- Crawler frames must be fully extended for all crane operations.
- When erecting and lowering the boom length of 59.5 m and 62.6 m, the blocks for erection must be placed at the end of the crawlers.

(Crane boom lifting)

- The total load that can be lifted is the value for weight of hook block, slings, and all other load handling accessories deducted from main boom ratings shown.

<Reference Information>

Main hoist loads

No. of Parts of Line	1	2	3	4	5
Maximum Loads (kN)	132	245	368	490	613
Maximum Loads (t)	13.5	25.0	37.5	50.0	62.5

No. of Parts of Line	6	7	8
Maximum Loads (kN)	735	858	981
Maximum Loads (t)	75.0	87.5	100.0

Auxiliary hoist loads

No. of Parts of Line	1
Maximum Loads (kN)	132
Maximum Loads (t)	13.5

Third hoist loads

No. of Parts of Line	2	3	4	5	6
Maximum Loads (kN)	216	324	431	539	647
Maximum Loads (t)	22.0	33.0	44.0	55.0	66.0

*One part of line on hook is not allowed to use.

Weight of hook block				
Hook Block	100 t	50 t	35 t	Ball Hook
Weight (t)	1.73	0.85	0.70	0.45

Operation of this equipment in excess of rated loads or disregard of instruction voids the warranty.

LIFTING CAPACITIES



Crane Boom Lifting Capacities

Counterweight: 37.1 t
Carbody Weight: 14.6 t
Unit: metric ton

Working radius (m)	Boom length (m)											Boom length (m)	Working radius (m)
		13.8	16.9	19.9	23.0	26.0	29.1	32.1	35.2	38.2	41.2		
3.8	100.0												3.8
4.3	4.3m/90.0	4.3m/87.5	4.8m/78.0										4.3
5.0	74.0	74.0	73.5	5.4m/70.0	5.9m/61.5								5.0
6.0	61.5	61.5	61.5	61.5	61.0	6.4m/56.8							6.0
7.0	51.3	51.1	51.0	50.9	50.8	50.8	50.0	7.5m/45.0					7.0
8.0	42.4	42.2	42.1	42.0	41.9	41.8	41.8	41.7	41.3	8.5m/37.5			8.0
9.0	36.0	35.9	35.7	35.6	35.5	35.5	35.4	35.3	35.2	35.1			9.0
10.0	31.3	31.1	31.0	30.9	30.8	30.7	30.6	30.5	30.4	30.3			10.0
12.0	22.0	24.5	24.3	24.2	24.1	24.0	24.0	23.8	23.7	23.6			12.0
14.0	13.2m/18.7	20.1	19.9	19.8	19.7	19.6	19.5	19.4	19.2	19.2			14.0
16.0		15.8m/14.9	16.8	16.7	16.5	16.5	16.4	16.2	16.1	16.0			16.0
18.0			13.6	14.3	14.2	14.1	14.0	13.8	13.7	13.7			18.0
20.0			18.5m/12.5	12.5	12.4	12.3	12.2	12.0	11.9	11.8			20.0
22.0				21.1m/11.1	10.9	10.8	10.7	10.5	10.4	10.3			22.0
24.0					23.8m/9.8	9.6	9.5	9.3	9.2	9.1			24.0
26.0						8.7	8.5	8.3	8.2	8.1			26.0
28.0						26.4m/8.2	7.7	7.5	7.4	7.3			28.0
30.0							29.0m/7.3	6.8	6.7	6.6			30.0
32.0								31.7m/6.3	6.1	6.0			32.0
34.0									5.5	5.4			34.0
36.0									34.3m/5.5	4.9			36.0
38.0										37.0m/4.7			38.0
Reeves	8	7	7	6	5	5	4	4	4	3			Reeves

Working radius (m)	Boom length (m)								Boom length (m)	Working radius (m)
		44.3	47.3	50.4	53.4	56.5	59.5	62.6		
9.0	9.1m/34.6	9.6m/31.8							9.0	
10.0	30.2	30.1	10.1m/25.0	10.7m/25.0	11.2m/21.6	11.7m/20.1			10.0	
12.0	23.5	23.4	23.3	23.2	19.5	19.4	12.2m/18.0		12.0	
14.0	19.0	18.9	18.9	18.7	18.6	18.0	15.4		14.0	
16.0	15.9	15.7	15.7	15.5	15.4	15.0	14.5		16.0	
18.0	13.5	13.4	13.3	13.2	13.0	12.9	12.7		18.0	
20.0	11.6	11.5	11.5	11.3	11.2	11.0	10.9		20.0	
22.0	10.2	10.0	10.0	9.8	9.7	9.6	9.4		22.0	
24.0	9.0	8.8	8.8	8.6	8.5	8.4	8.2		24.0	
26.0	8.0	7.8	7.8	7.6	7.5	7.3	7.2		26.0	
28.0	7.1	7.0	6.9	6.8	6.6	6.5	6.3		28.0	
30.0	6.4	6.3	6.2	6.0	5.9	5.8	5.6		30.0	
32.0	5.8	5.6	5.6	5.4	5.3	5.1	5.0		32.0	
34.0	5.2	5.1	5.0	4.8	4.7	4.6	4.4		34.0	
36.0	4.8	4.6	4.5	4.4	4.2	4.1	3.9		36.0	
38.0	4.3	4.2	4.1	3.9	3.8	3.7	3.5		38.0	
40.0	39.6m/4.0	3.8	3.7	3.6	3.4	3.3	3.0		40.0	
42.0		3.5	3.4	3.2	3.0	2.9	2.6		42.0	
44.0		42.2m/3.5	3.1	2.9	2.7	2.5			44.0	
46.0			44.9m/3.0	2.5					46.0	
Reeves	3	3	2	2	2	2	2		Reeves	

Note:

Ratings according to Japanese Construction Codes for Mobile Cranes and Japanese Safety Ordinance on Cranes, etc.

Ratings shown in are determined by the strength of the boom or other structural components.

Refer to notes P8.

Lifting capacities may vary depending on hook used or with/without auxiliary sheave.

Please refer rated chart in operator's cabin.

SUPPLEMENTAL DATA FOR CLAMSHELL RATING CHART

- Operating radius is the horizontal distance from centerline of rotation to a vertical line through the center of gravity of the load.
- Deduct weight of bucket, slings and all other load handling accessories from main boom ratings shown.
- Ratings shown are based on freely suspended loads and make no allowance for such factors as wind effect on lifted load, ground conditions, out-of-level, operating speeds or any other condition that could be detrimental to the safe operation of this equipment. The operator, therefore, has the responsibility to judge the existing conditions and reduce lifted loads and operating speeds accordingly.
- Rated loads do not exceed 66% of minimum tipping loads.
- Ratings are for operation on a firm and level surface, up to 1% gradient.
- At radii and boom lengths where no ratings are shown on chart, operation is not intended nor approved.
- Boom inserts and guy lines must be arranged as shown in the "operator's manual".
- Boom hoist reeving is 10 part line.
- Gantry must be in raised position for all conditions.
- Boom backstops are required for all boom lengths.
- The boom should be erected over the front of the crawlers, not laterally.
- Crawler frames must be fully extended for all crane operations.

(Clamshell bucket lifting)

- The total load that can be lifted is the value for weight of bucket, slings, and all other load handling accessories deducted from main boom ratings shown.
- The weight of bucket and materials must not exceed rated load.
- Optimum bucket should be required according to material.
- $\text{Bucket capacity (m}^3\text{)} \times \text{specified gravity of material (ton/m}^3\text{)} + \text{bucket weight (ton)} = \text{rated load.}$
- Bucket weight must also be decreased according to operating cycle and bucket lowering height.
- Rated loads are determined by stability and boom strength. During simultaneous operations of boom and swing, rapid acceleration or deceleration must be avoided.
- Do not attempt to cast the bucket while swinging or diagonal draw-cutting.

<Reference Information>

Main hoist loads

No. of Parts of Line	1
Maximum Loads (kN)	122
Maximum Loads (t)	12.5

Assembling the counterweight

(STD)

37.1 ton counterweight

14.6 ton carbody weight

No.6		No.7
No.4		No.5
No.3		
No.2		
No.1		

Counterweights



Carbody weights

Operation of this equipment in excess of rated loads or disregard of instruction voids the warranty.

LIFTING CAPACITIES



Clamshell Rating Charts Crane Boom Capacities

Counterweight: 37.1 t
Carbody Weight: 14.6 t
Unit: metric ton

Load radius (m) \ Boom length (m)	13.8	16.9	19.9	23.0	26.0				Boom length (m) \ Load radius (m)
6.0	12.5								6.0
7.0	12.5	12.5							7.0
8.0	12.5	12.5	12.5						8.0
9.0	12.5	12.5	12.5	11.4					9.0
10.0	12.5	12.5	12.5	11.4	9.4				10.0
12.0	12.5	12.5	12.5	11.4	9.4				12.0
14.0		12.2	12.2	11.4	9.3				14.0
16.0			10.7	10.7	9.1				16.0
18.0			17.0m/9.9	9.5	8.6				18.0
20.0				8.2	8.1				20.0
22.0					7.3				22.0
24.0									24.0
26.0									26.0
28.0									28.0
30.0									30.0
32.0									32.0
Reeves	1	1	1	1	1				Reeves

Note:
Please refer rated chart in operator's cabin.

SUPPLEMENTAL DATA FOR REDUCED WEIGHTS RATING CHART

- Ratings according to Japanese construction codes for mobile cranes.
- Operating radius is the horizontal distance from centerline of rotation to a vertical line through the center of gravity of the load.
- Deduct weight of hook block(s), slings and all other load handling accessories from main boom ratings shown.
- Ratings shown are based on freely suspended loads and make no allowance for such factors as wind effect on lifted load, ground conditions, out-of-level, operating speeds or any other condition that could be detrimental to the safe operation of this equipment. The operator, therefore, has the responsibility to judge the existing conditions and reduce lifted loads and operating speeds accordingly.
- Ratings are for operation on a firm and level surface, up to 1% gradient.
- At radii and boom lengths where no ratings are shown on chart, operation is not intended nor approved.
- Boom inserts and guy lines must be arranged as shown in the "operator's manual".
- Boom hoist reeving is 10 part line.
- Gantry must be in raised position for all conditions.
- Boom backstops are required for all boom lengths.
- The boom should be erected over the front of the crawlers, not laterally.
- Ratings inside of boxes are limited by strength of materials.
- The minimum rated load is 1.5 (ton).
- Crawler frames must be fully extended for all crane operations.

(Crane boom lifting)

The total load that can be lifted is the value for weight of hook block, slings, and all other load handling accessories deducted from main boom ratings shown.

<Reference Information>

Main hoist loads

No. of Parts of Line	1	2	3	4	5
Maximum Loads (kN)	132	245	368	490	613
Maximum Loads (t)	13.5	25.0	37.5	50.0	62.5

No. of Parts of Line	6	7	8
Maximum Loads (kN)	735	858	981
Maximum Loads (t)	75.0	87.5	100.0

Auxiliary hoist loads

No. of Parts of Line	1
Maximum Loads (kN)	132
Maximum Loads (t)	13.5

Weight of hook block				
Hook Block	100 t	50 t	35 t	Ball Hook
Weight (t)	1.73	0.85	0.70	0.45

Assembling the counterweight

26.8 ton counterweight
without carbody weight

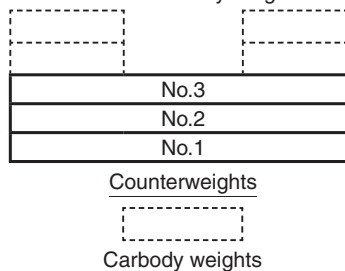

The lifting capacity does not change due to the type of counterweights.

Operation of this equipment in excess of rated loads or disregard of instruction voids the warranty.

LIFTING CAPACITIES



Reduced Weights Rating Charts Crane Boom Lifting Capacities

Counterweight: 26.8 t
Without Carbody Weight
Unit: metric ton

Load radius (m)	Boom length (m)	13.8	16.9	19.9	23.0	26.0	29.1	32.1	35.2	38.2	41.2	44.3	47.3	50.4	53.4	Boom length (m)	Load radius (m)								
		3.8	4.3	5.0	6.0	7.0	8.0	9.0	10.0	12.0	14.0	16.0	18.0	20.0	22.0			24.0	26.0	28.0	30.0	32.0	34.0	36.0	38.0
3.8	3.8m/90.0																3.8								
4.3	80.0	4.3m/80.0	4.8m/66.7														4.3								
5.0	62.3	62.3	62.2	5.4m/54.4	5.9m/46.9												5.0								
6.0	46.0	46.0	45.8	45.8	45.8	6.4m/41.1											6.0								
7.0	36.3	36.2	36.1	36.0	35.9	35.8	7.0m/35.8	7.5m/32.1									7.0								
8.0	29.8	29.7	29.6	29.5	29.4	29.3	29.3	29.2	8.0m/29.0	8.5m/26.5							8.0								
9.0	25.3	25.2	25.0	24.9	24.8	24.7	24.7	24.5	24.4	24.4	9.1m/23.8	9.6m/21.9					9.0								
10.0	21.9	21.7	21.6	21.5	21.4	21.3	21.2	21.1	21.0	21.0	20.8	20.7	10.1m/20.3	10.7m/18.5			10.0								
12.0	17.1	17.0	16.8	16.7	16.6	16.5	16.4	16.3	16.2	16.1	16.0	15.9	15.9	15.7			12.0								
14.0	13.2m/15.2	13.9	13.7	13.6	13.4	13.3	13.3	13.1	13.0	12.9	12.8	12.7	12.6	12.5			14.0								
16.0		15.8m/11.8	11.4	11.3	11.2	11.1	11.0	10.8	10.7	10.7	10.5	10.4	10.4	10.2			16.0								
18.0			9.8	9.7	9.5	9.4	9.3	9.1	9.0	9.0	8.8	8.7	8.7	8.5			18.0								
20.0			18.5m/9.5	8.4	8.2	8.1	8.0	7.8	7.7	7.7	7.5	7.4	7.3	7.2			20.0								
22.0				21.1m/7.8	7.2	7.1	7.0	6.8	6.7	6.6	6.4	6.3	6.3	6.1			22.0								
24.0					23.8m/6.4	6.2	6.1	5.9	5.8	5.7	5.6	5.4	5.4	5.2			24.0								
26.0						5.5	5.4	5.2	5.1	5.0	4.9	4.7	4.7	4.5			26.0								
28.0						26.4m/5.4	4.9	4.7	4.5	4.4	4.3	4.1	4.1	3.9			28.0								
30.0							29.0m/4.6	4.2	4.0	3.9	3.7	3.6	3.6	3.4			30.0								
32.0								31.7m/3.8	3.6	3.5	3.3	3.2	3.1	3.0			32.0								
34.0									3.2	3.1	2.9	2.8	2.7	2.6			34.0								
36.0									34.3m/3.2	2.8	2.6	2.5	2.4	2.2			36.0								
38.0										37.0m/2.6	2.3	2.1	2.0	38.0m/1.8			38.0								
40.0											39.6m/2.1	1.8	40.0m/1.7				40.0								
42.0												1.5					42.0								
44.0												42.2m/1.5					44.0								
Reeves		8	7	6	5	4	4	3	3	3	3	2	2	2	2		Reeves								

Note:

Ratings according to Japanese Construction Codes for Mobile Cranes and Japanese Safety Ordinance on Cranes, etc.

Ratings shown in are determined by the strength of the boom or other structural components.

Lifting capacities may vary depending on hook used or with/without auxiliary sheave.

Please refer rated chart in operator's cabin.

SUPPLEMENTAL DATA FOR BARGE RATING CHART

- Operating radius is the horizontal distance from centerline of rotation to a vertical line through the center of gravity of the load.
- Deduct weight of hook block (s), slings and all other load handling accessories from main boom ratings shown.
- Condition of barge stability this rating chart were determined under the condition below. The stability of barge shall meet below condition. During operation the machinery static inclination against horizontal level.

(A) Both sides (right & left) of machine

Maximum inclination shall be within 1.5 Degrees

(B) Front & backward of machine

Maximum inclination shall be within 3.0 Degrees

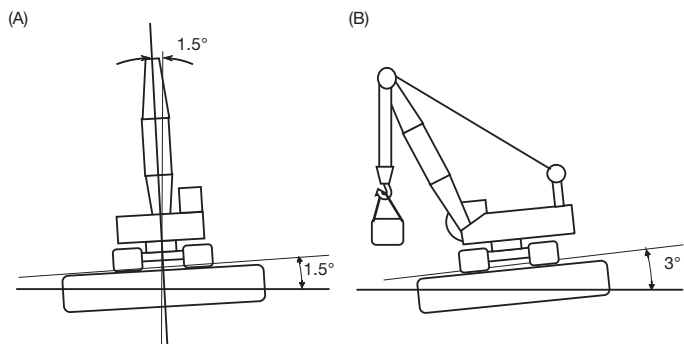
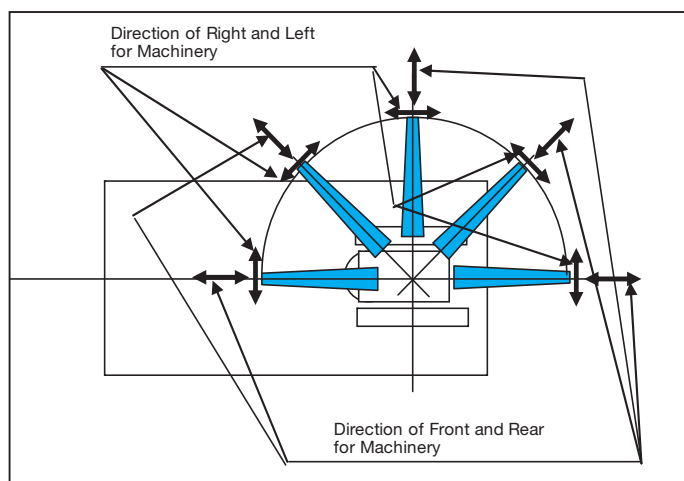

- Working area shall be inshore and smooth water.
- Applicable regulations for structure Japanese construction codes for mobil crane
 - ※ Regulation of class of shipping (abs, lloyd, bv, nk, etc) are not adapted.
- At radii and boom lengths where no ratings are shown on chart, operation is not intended nor approved.
- Boom inserts and guy lines must be arranged as shown in the "operator's manual".
- Boom hoist reeving is 10 part line.
- Gantry must be in raised position for all conditions.
- Boom backstops are required for all boom lengths.

- The boom should be erected over the front of the crawlers, not laterally.
- Ratings inside of boxes are limited by strength of materials.
- The minimum rated load is 1.5 (ton).
- Crawler frames must be fully extended for all crane operations.
- The machinery should be fastened to the deck of the barge to prevent tip over and sliding.
- Towing area
 - Towing area shall be within coastal area and quiet wave condition. Offshore and open sea is not considered for this machinery. Depend on the height of wave, counterweight shall be reduced during towing.

(Crane boom)

- The total load that can be lifted is the value for weight of hook block, slings, and all other load handling accessories deducted from main boom ratings shown.

<Reference Information>

Main hoist loads

No. of Parts of Line	1	2	3	4	5
Maximum Loads (kN)	132	245	368	490	588
Maximum Loads (t)	13.5	25.0	37.5	50.0	60.0

Auxiliary hoist loads

No. of Parts of Line	1
Maximum Loads (kN)	132
Maximum Loads (t)	13.5

Weight of hook block				
Hook Block	100 t	50 t	35 t	Ball Hook
Weight (t)	1.73	0.85	0.70	0.45

Operation of this equipment in excess of rated loads or disregard of instruction voids the warranty.

LIFTING CAPACITIES



Barge Rating Chart Crane Boom Lifting Capacities

Counterweight: 37.1 t
Carbody Weight: 14.6 t
Crawler Fully Extended
Unit: metric tons

Load radius (m) \ Boom length (m)	13.8	16.9	19.9	23.0	26.0	29.1	32.1	35.2	38.2	Boom length (m) \ Load radius (m)
4.0	4.7m/60.0									4.0
5.0	55.0	5.2m/49.4	5.9m/43.5							5.0
6.0	43.1	42.9	42.8	6.6m/38.4						6.0
7.0	36.7	36.4	36.2	36.1	7.3m/34.3	7.9m/31.3				7.0
8.0	31.8	31.5	31.4	31.2	31.0	30.9	8.6m/28.2			8.0
9.0	27.9	27.7	27.6	27.5	27.3	27.1	26.9	9.3m/25.7		9.0
10.0	23.2	24.6	24.5	24.4	24.2	24.0	23.8	23.7	10.0m/23.6	10.0
12.0	16.5	18.2	19.6	19.7	19.6	19.5	19.4	19.1	19.0	12.0
14.0	13.2m/13.2	13.9	15.1	16.1	15.9	15.8	15.8	15.6	15.5	14.0
16.0		15.8m/11.1	12.0	12.9	13.3	13.2	13.1	13.0	12.8	16.0
18.0			9.7	10.5	11.1	11.3	11.2	11.0	10.9	18.0
20.0			18.5m/9.1	8.6	9.2	9.7	9.7	9.5	9.4	20.0
22.0				21.1m/7.8	7.7	8.2	8.5	8.3	8.2	22.0
24.0					23.8m/6.6	6.9	7.3	7.3	7.2	24.0
26.0						5.9	6.3	6.5	6.4	26.0
28.0						26.4m/5.7	5.4	5.6	5.7	28.0
30.0							29.0m/5.0	4.8	5.1	30.0
32.0								31.7m/4.3	4.5	32.0
34.0									3.9	34.0
36.0									34.3m/3.8	36.0
Reeves	5	4	4	4	3	3	3	3	2	Reeves

Note:

Ratings according to Japanese construction codes for mobile cranes and Japanese safety ordinance on cranes, etc.

Ratings shown in are determined by the strength of the boom or other structural components.

Lifting capacities may vary depending on hook used or with/without auxiliary sheave.

Please refer rated chart in operator's cabin.

TRANSPORTATION PLAN

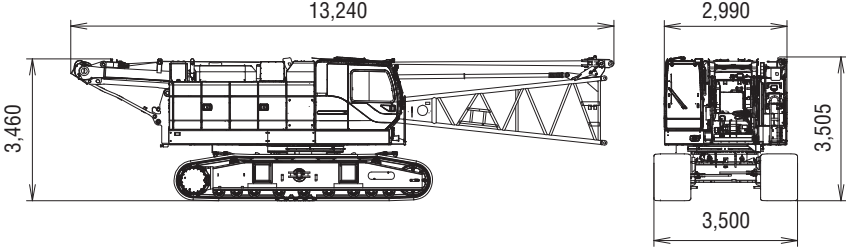
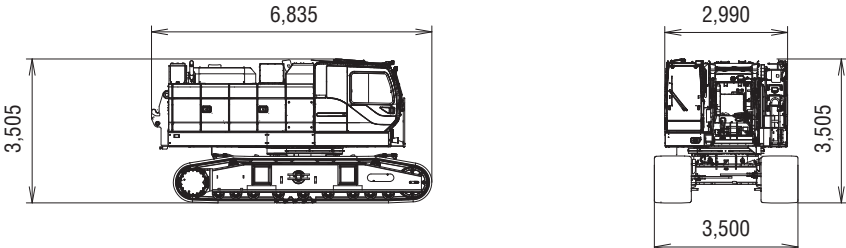
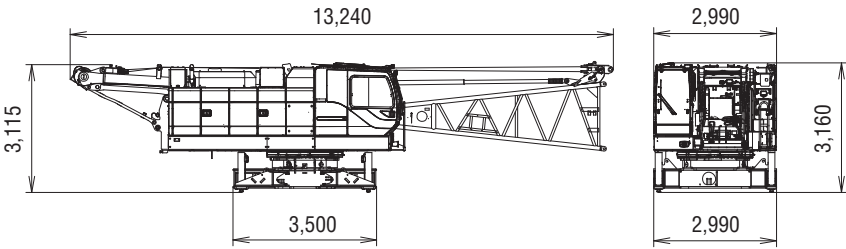
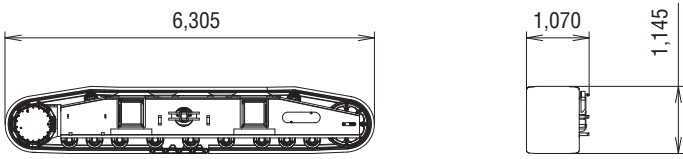
Name	Dimension (mm)	Weight (kg)
Base Machine <ul style="list-style-type: none"> • Boom base • Gantry • Crawler • Crane backstop • Third winch • Wire rope (Front / rear / third boom hoist) 		51,600
Base Machine <ul style="list-style-type: none"> • Crawler • Third winch • Wire rope (Front / rear / third drum) 		47,600
Base Machine <ul style="list-style-type: none"> • Boom base • Gantry • Third winch • Wire rope (Front / rear / third boom hoist) • Crane backstop • Without crawler 		31,000
Crawler		10,300

PARTS AND ATTACHMENTS

Base Machine

Boom base, Gantry, Crawler, Crane backstop, Third winch
Wire rope (Front/rear/third/boom hoist),
Weight: 51,600 kg Width: 3,500 mm

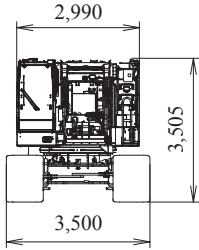
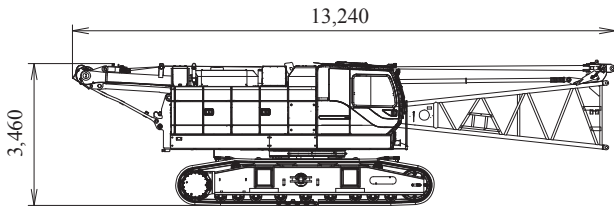

Crawler

Weight: 10,300 kg

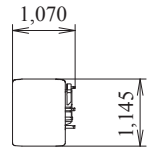
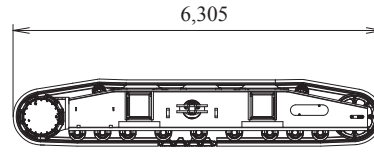

Counterweight No.1

Weight: 9,920 kg

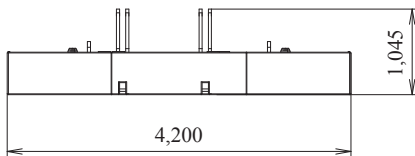
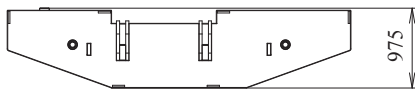

Counterweight No.2

Weight: 8,940 kg

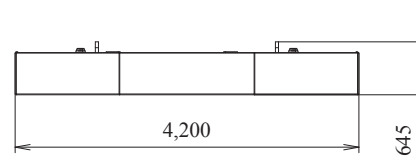
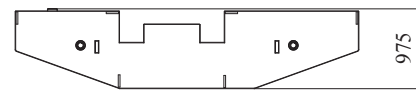

Counterweight No.3

Weight: 7,960 kg

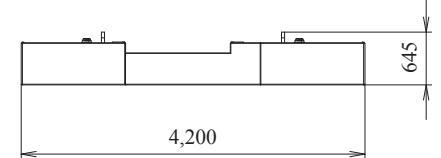
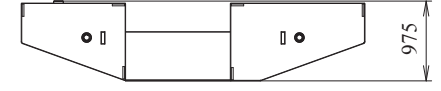

Counterweight No.4 (L)

Weight: 2,350 kg

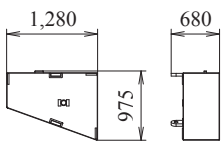

Counterweight No.5 (R)

Weight: 3,740 kg

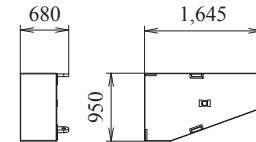

Counterweight No.6 (L)

Weight: 1,740 kg

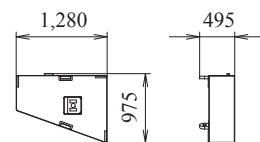

Counterweight No.7 (R)

Weight: 2,490 kg

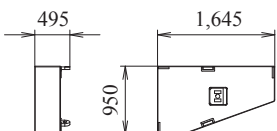

Carbody Weight

Weight: 7,250 kg

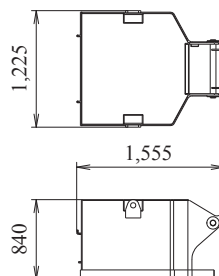

Gantry

Weight: 1,400 kg

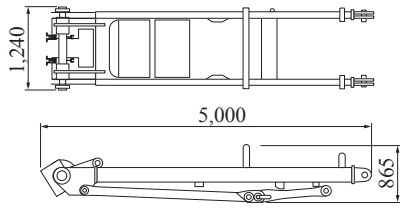

Insert Boom

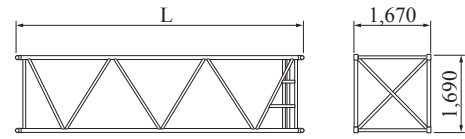

	L (mm)	Weight (kg)*
3.0m	3,170	500
6.1m	6,210	800
9.1m	9,260	1100

*with boom guy cables

Boom Top

Weight: 1,720 kg (with boom guy cables)

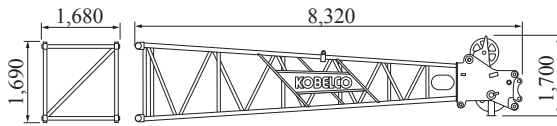

Boom Base

Weight: 1,580 kg

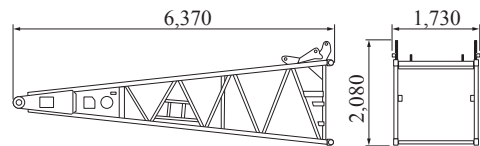

Crane Backstop

Weight: 130 kg

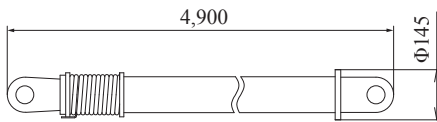

Upper Spreader

Weight: 300 kg

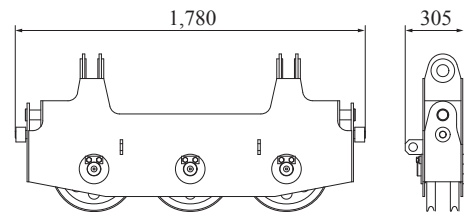

Lower Spreader

Weight: 200 kg

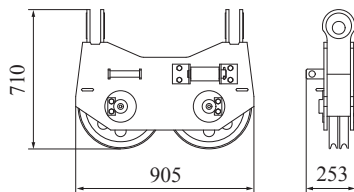

Ball Hook

Weight: 450 kg

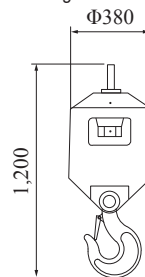

35 t Hook

Weight: 700 kg

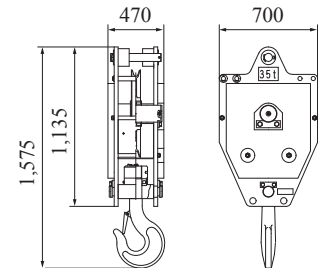

50 t Hook

Weight: 850 kg

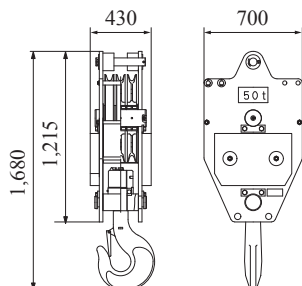

100 t Hook

Weight: 1,730 kg

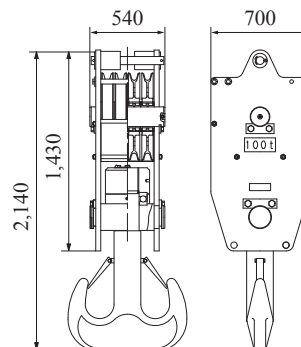

Note: This catalog may contain photographs of machines with specifications, attachments and optional equipment not certified for operation in your country. Please consult KOBELCO for those items you may require. Due to our policy of continual product improvements all designs and specifications are subject to change without advance notice.

Copyright by KOBELCO CRANES CO., LTD. No part of this catalog may be reproduced in any manner without notice.

KOBELCO CRANES CO., LTD.

17-1, Higashigotanda 2-chome, Shinagawa-ku, Tokyo 141-8626 JAPAN

Tel: +81-3-5789-2130 Fax: +81-3-5789-3372

URL: <http://www.kobelco-cranes.com/>

Inquiries To: